

GLOBAL PUMP SOLUTION DOOCH

60Hz



VERTICAL MULTISTAGE PUMP

XR(L) SERIES

Feature

XR, XRL pumps are vertical non-self priming multistage centrifugal pump of in-line design, which is driven by a standard electric motor. The motor output shaft directly connects with the pump shaft through a coupling. The pressure-resistant cylinder and flow passage components are fixed between the pump head and the pump casing by means of staybolts. The pump casing has suction and discharge ports on the same level (in-line).

All pumps are equipped with a cartridge mechanical seal for easy maintenance.

XR, XRL pumps are available in various sizes and various numbers of stage to provide the required flow and pressure. The pumps are available with DOOCH variable frequency drive (XQ/NSQ Drive).

Definition of Model

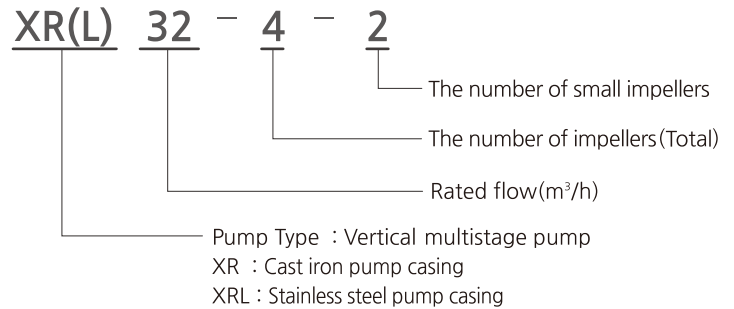

Motor

IEC - Standard squirrel-cage rotor 3 phase electric motor

Motor type : TEFC

Protection class : IP54~55

Insulation class : F

Standard voltage : 7.5kW and below - $\phi 3 \times 220/380V$

11kW and above - $\phi 3 \times 380V$

(The standard voltage can be changed as per request.)



Operation Conditions

- Available liquids :
Thin, clean, non-flammable and non-explosive liquid containing no solid granules and fibers.
- Liquid temperature : Normal temperature : $-15^{\circ}C \sim +70^{\circ}C$
Hot water type : $+70^{\circ}C \sim +120^{\circ}C$
- Ambient temperature : up to $+40^{\circ}C$
- Altitude : up to 1000m

Application

The pumps are suitable for liquid transfer in

- Water supply systems
- Washing systems
- Cooling and air conditioning systems
- Water treatment systems
- Fire fighting systems
- Industrial plants
- Boiler feed systems

Sectional Drawing

XR(L) 1, 3, 5, 10, 15, 20

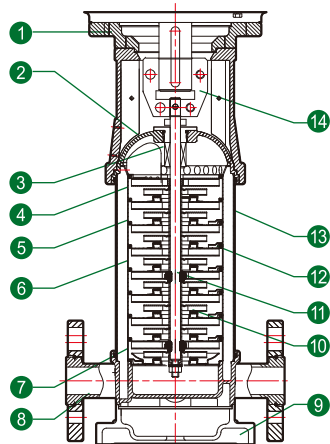

NO.	PARTS	MATERIAL	EN/DIN	AISI/ASTM
1	Motor bracket	GCD450	EN-GJS-450	A536-65-45
2	Pump head(XR)	GC250	EN-GJS-250C	A48-CL35
	Pump head(XRL)			
3	Mechanical seal	SIC/CARBON/VITON		
4	Top diffuser	STS304	EN10088 1,4301	A240-304
5	Diffuser	STS304	EN10088 1,4301	A240-304
6	Support diffuser	STS304	EN10088 1,4301	A240-304
7	Inducer	STS304	EN10088 1,4301	A240-304
8	Pump casing(XR)	GC250	EN-GJS-250C	A48-CL35
	Pump casing(XRL)			
9	Base plate	GC250	EN-GJS-250C	A48-CL35
10	Impeller	STS304	EN10088 1,4301	A240-304
11	Shaft	STS304	EN10088 1,4301	A276-304
12	Impeller sleeve	STS304	EN10088 1,4301	A240-304
13	Cylinder	STS304	EN10088 1,4301	A240-304
14	Coupling	GCD450	EN-GJS-450	A536-65-45
	Rubber part	EPDM		

* Intermediate flange: GC250

XR(L) 32, 45, 64

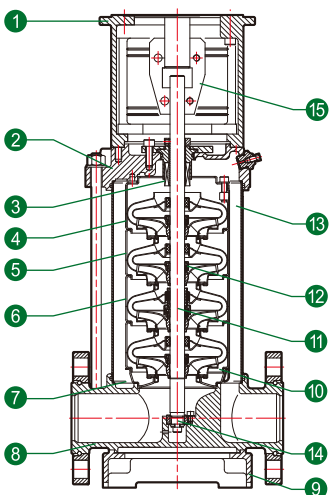

NO.	PARTS	MATERIAL	EN/DIN	AISI/ASTM
1	Motor bracket	GCD450	EN-GJS-450	A536-65-45
2	Pump head(XR)	GC250	EN-GJS-250C	A48-CL35
	Pump head(XRL)	SSC13	EN10283 1,4408	A351-CF8
3	Mechanical seal	SIC/CARBON/VITON		
4	Top diffuser	STS304	EN10088 1,4301	A240-304
5	Support diffuser	STS304	EN10088 1,4301	A240-304
6	Diffuser	STS304	EN10088 1,4301	A240-304
7	Inducer	STS304	EN10088 1,4301	A240-304
8	Pump casing(XR)	GC250	EN-GJS-250C	A48-CL35
	Pump casing(XRL)	SSC13	EN10283 1,4408	A351-CF8
9	Base plate	GC250	EN-GJS-250C	A48-CL35
10	Impeller	STS304	EN10088 1,4301	A240-304
11	Shaft	STS304	EN10088 1,4301	A276-304
12	Intermediate bearing	Tungsten carbide		
13	Cylinder	STS304	EN10088 1,4301	A240-304
14	Bottom bearing	Tungsten carbide		
15	Coupling	GCD450	EN-GJS-450	A536-65-45
	Rubber part	EPDM		

* Intermediate flange: GC250

XR(L) 95, 125, 155, 185

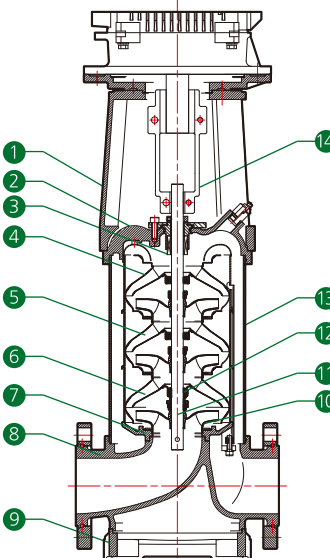

NO.	PARTS	MATERIAL	EN/DIN	AISI/ASTM
1	Motor bracket	GCD500	EN-GJS-500	A536-70-50
2	Pump head(XR)	GCD500	EN-GJS-500-7C	A536-70-50-05
	Pump head(XRL)	SSC13	EN10283 1,4408	A351-CF8
3	Mechanical seal	SIC/CARBON/VITON		
4	Top diffuser	STS304	EN10088 1,4301	A240-304
5	Support diffuser	STS304	EN10088 1,4301	A240-304
6	Diffuser	STS304	EN10088 1,4301	A240-304
7	Inducer	STS304	EN10088 1,4301	A240-304
8	Pump casing(XR)	GCD500	EN-GJS-500-7C	A536-70-50-05
	Pump casing(XRL)	SSC13	EN10283 1,4408	A351-CF8
9	Base plate	GCD500	EN-GJS-500	A536-70-50
10	Impeller	STS304	EN10088 1,4301	A240-304
11	Shaft	STS304	EN10088 1,4301	A276-304
12	Intermediate bearing	Tungsten carbide		
13	Cylinder	STS304	EN10088 1,4301	A240-304
14	Coupling	GCD450	EN-GJS-450	A536-65-45
	Rubber part	EPDM		

* Intermediate flange: GC250/GCD500

Performance Range

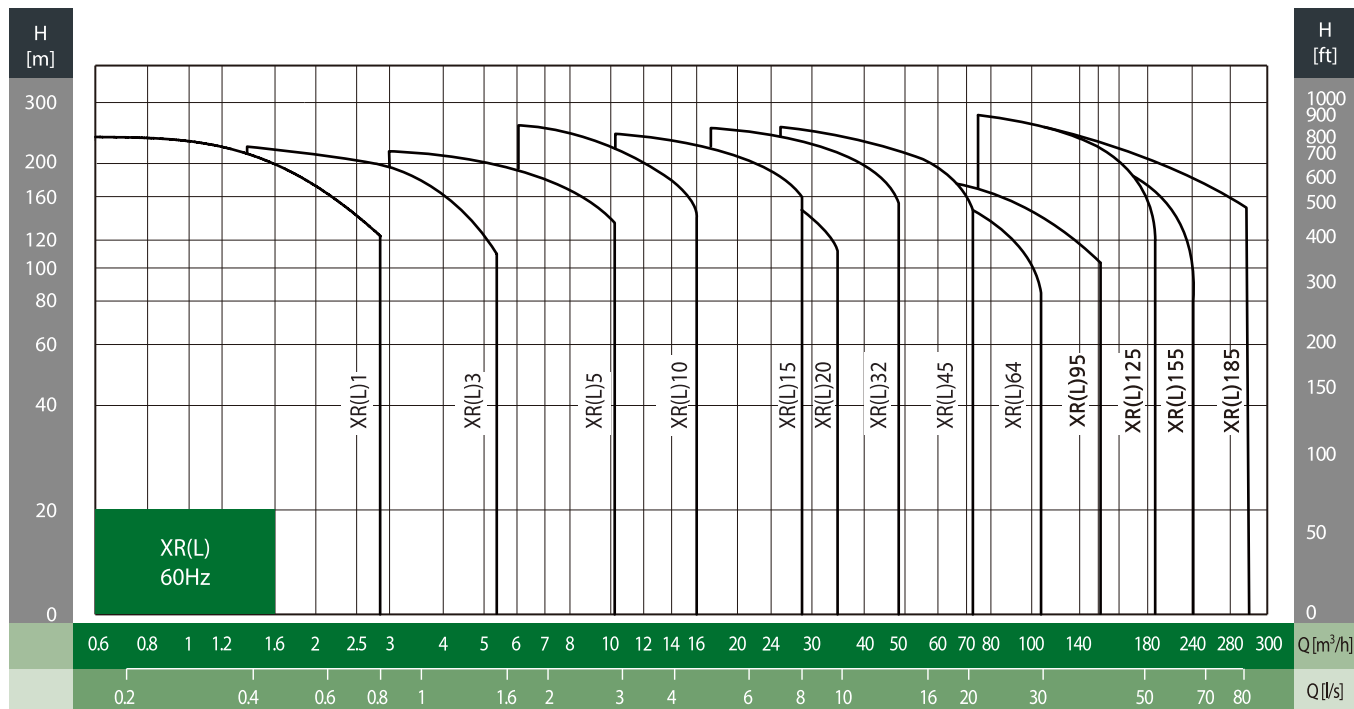

Specification

DESCRIPTION	XR(L)1	XR(L)3	XR(L)5	XR(L)10	XR(L)15	XR(L)20	XR(L)32	XR(L)45	XR(L)64	XR(L)95	XR(L)125	XR(L)155	XR(L)185
Rated flow [m³/h]	1	3	5	10	15	20	32	45	64	95	125	155	185
Flow range [m³/h]	0.8-2.9	1.4-5.4	3-10.2	6-16	10-29	12-35	18-48	25-72	36-108	55.5-150	75-190	90-240	110-290
Max. pressure [bar]	25						30						40
Motor power [kW]	0.75-3.7	0.75-3.7	0.75-7.5	1.5-11	3.7-18.5	3.7-18.5	5.5-30	5.5-45	7.5-45	11-55	15-110	18.5-110	30-132
Liquid Temperature [°C]	-15~+120°C												
Ambient Temperature [°C]	Max. 40°C												
Pump Type	Vertical Multistage Centrifugal Pump												
XR	●	●	●	●	●	●	●	●	●	●	●	●	●
XRL	●	●	●	●	●	●	●	●	●	●	●	●	●
DIN Flange	DN25	DN25	DN32	DN40	DN50	DN50	DN65	DN80	DN100	DN100	DN150	DN150	DN200

Performance Curve

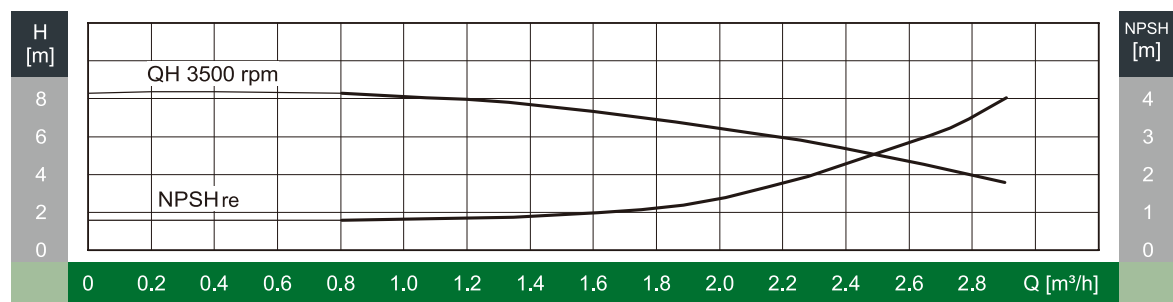
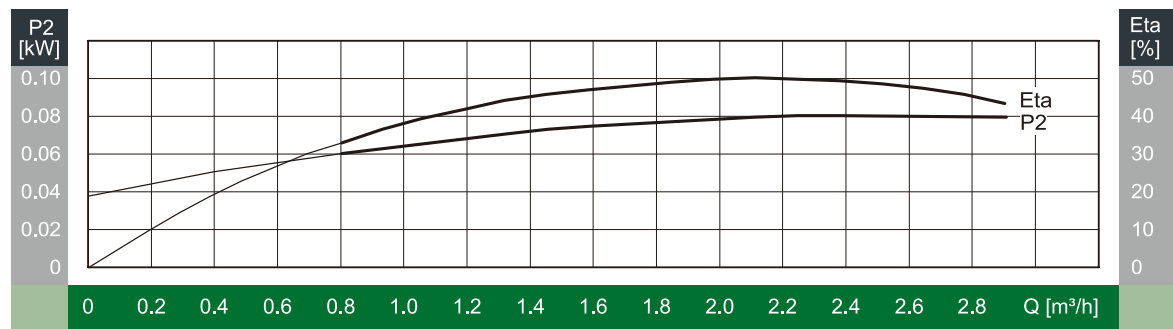
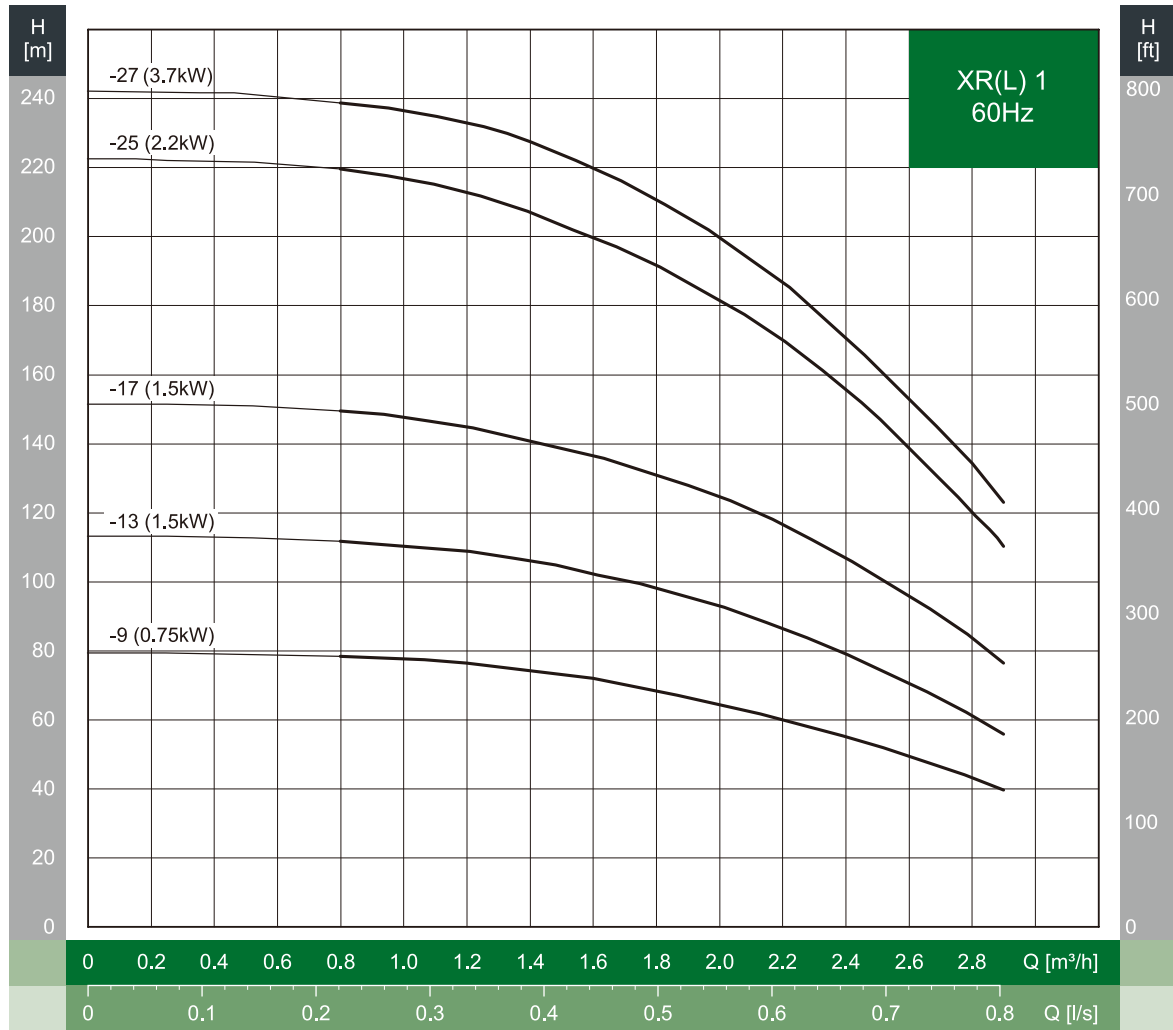

※ Given that the product mentioned above is customised, please contact the main office.

Outline Drawing

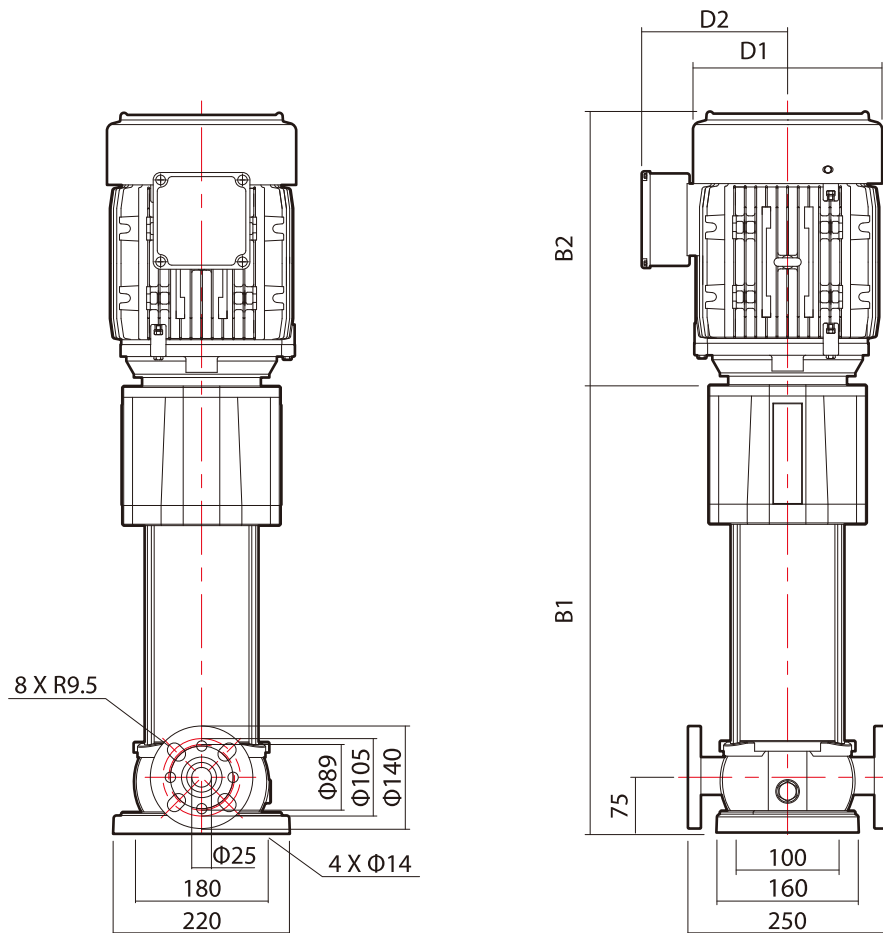

Dimension / Weight

MODEL	POWER		DIMENSION (UNIT: mm)					WEIGHT (kg)
	kW	HP	B1	B2	B1+B2	D1	D2	
XR(L) 1-9	0.75	1	474.5	255	729.5	170	160	26
XR(L) 1-13	1.5	2	546.5	315	861.5	187	170	30
XR(L) 1-17	1.5	2	618.5	315	933.5	187	170	38
XR(L) 1-25	2.2	3	762.5	315	1077.5	187	170	42
XR(L) 1-27	3.7	5	798.5	330	1128.5	227	220	45

※ Given that the product mentioned above is customised, please contact the main office.

Performance Curve

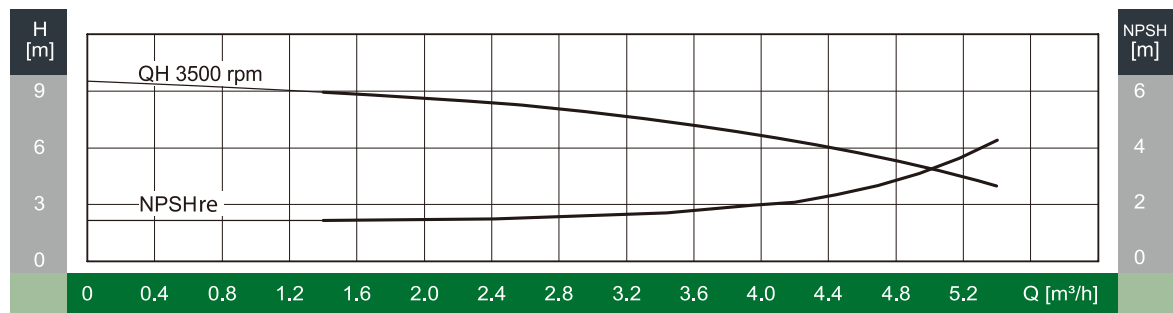
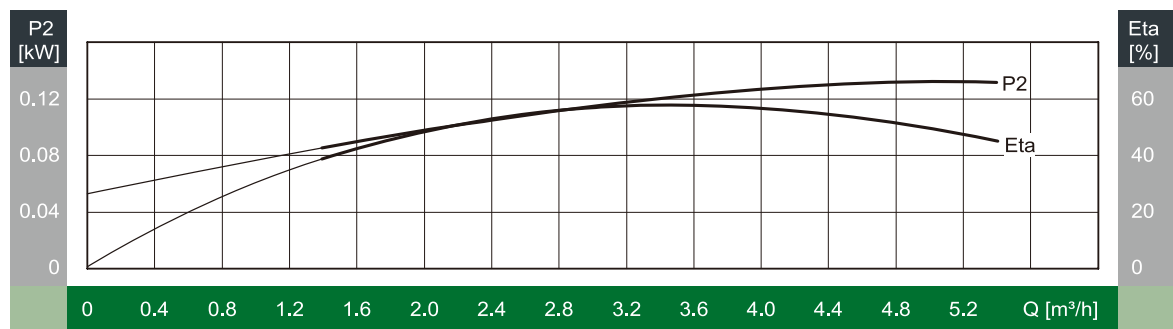
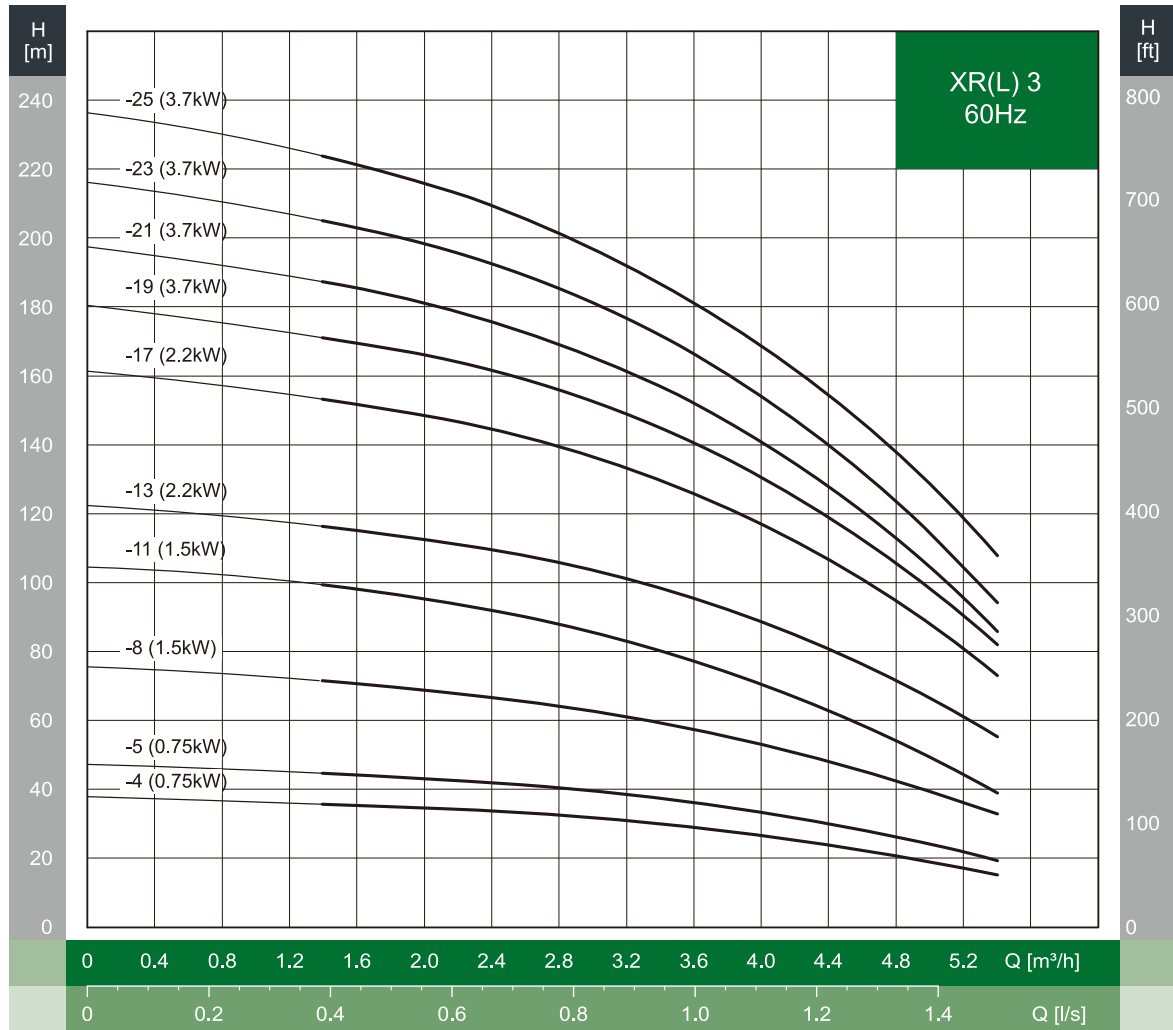

Outline Drawing

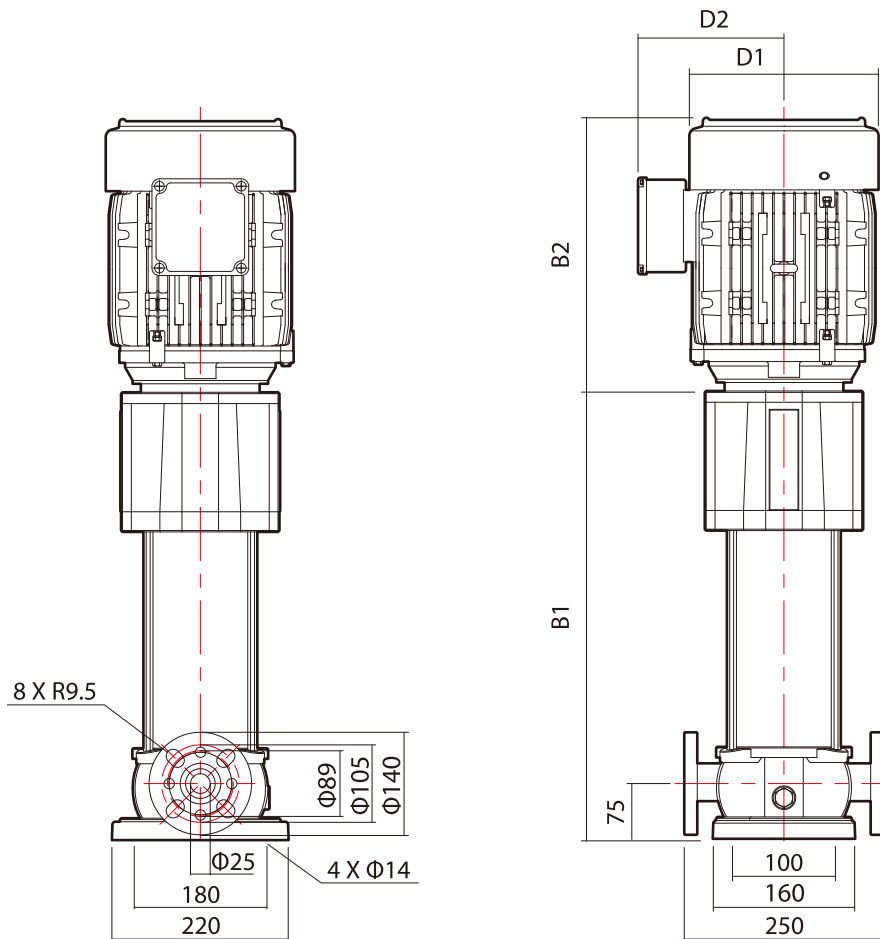

Dimension / Weight

MODEL	POWER		DIMENSION (UNIT: mm)					WEIGHT (kg)
	kW	HP	B1	B2	B1+B2	D1	D2	
XR(L) 3-4	0.75	1	384.5	255	639.5	170	160	22
XR(L) 3-5	0.75	1	402.5	255	657.5	170	160	24
XR(L) 3-8	1.5	2	456.5	315	771.5	187	170	28
XR(L) 3-11	1.5	2	510.5	315	825.5	187	170	35
XR(L) 3-13	2.2	3	546.5	315	861.5	187	170	37
XR(L) 3-17	2.2	3	618.5	315	933.5	187	170	38
XR(L) 3-19	3.7	5	654.5	330	984.5	227	220	46
XR(L) 3-21	3.7	5	690.5	330	1020.5	227	220	46
XR(L) 3-23	3.7	5	726.5	330	1056.5	227	220	47
XR(L) 3-25	3.7	5	762.5	330	1092.5	227	220	57

Performance Curve

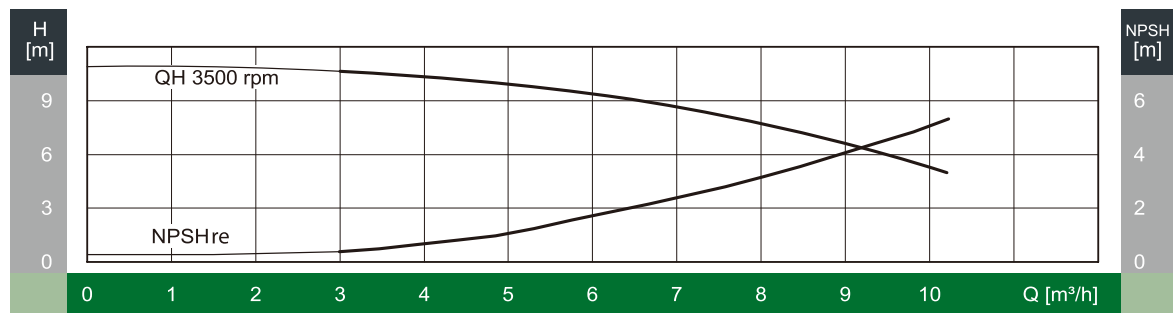
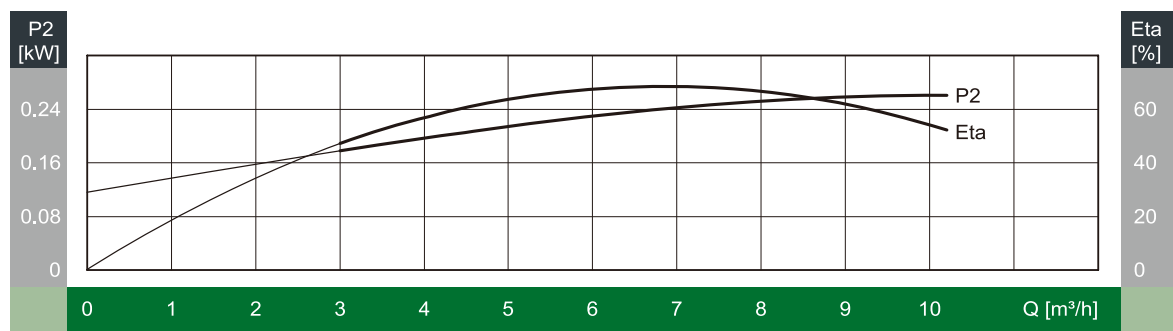
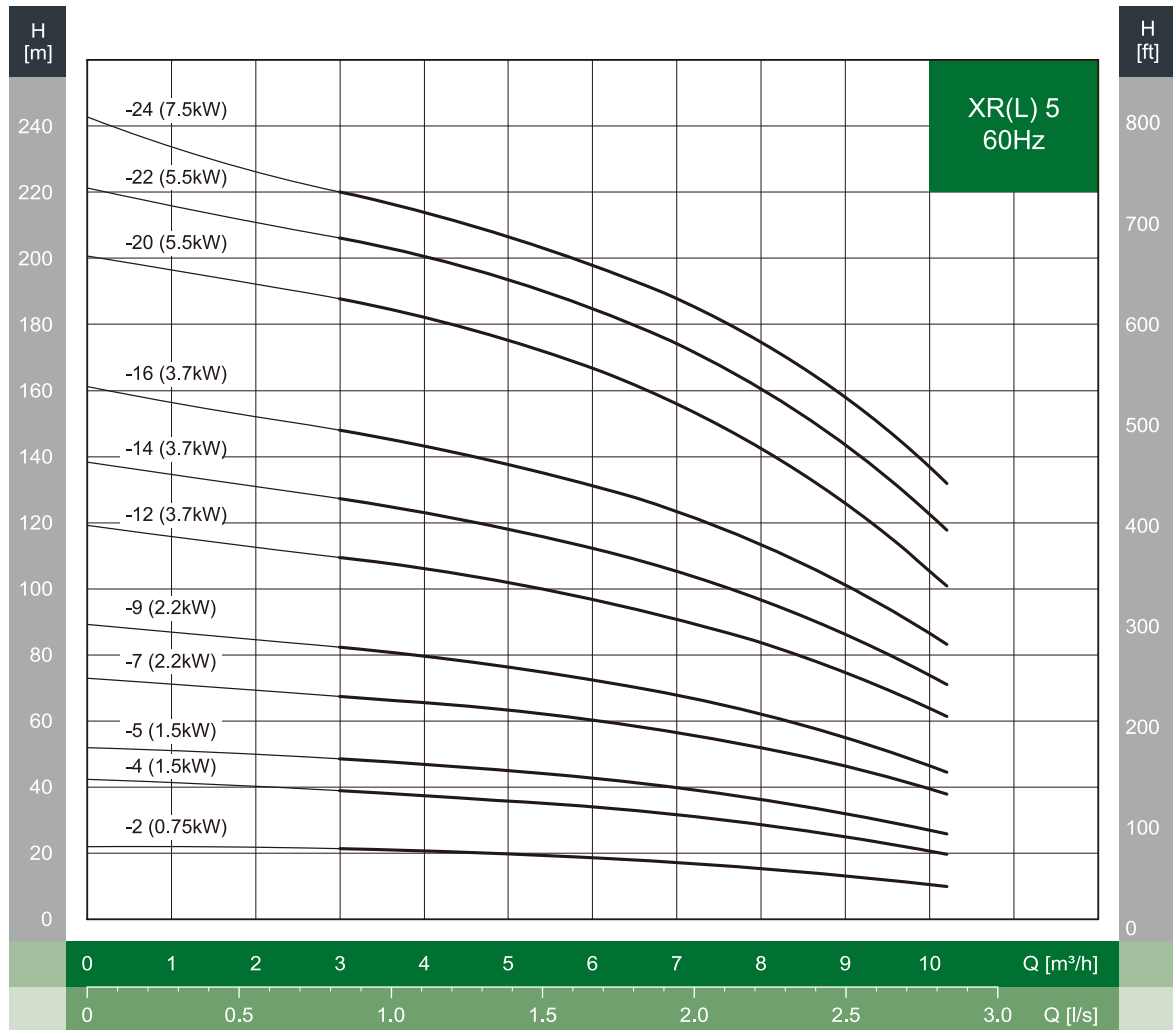

Outline Drawing

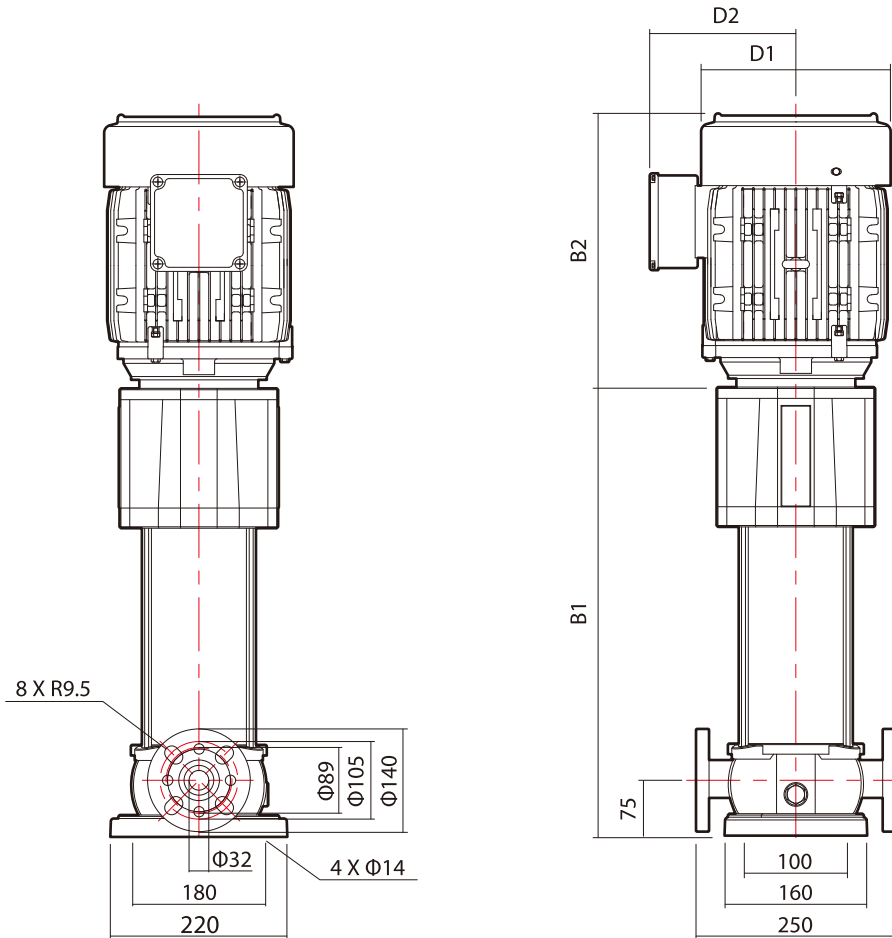

Dimension / Weight

MODEL	POWER		DIMENSION (UNIT: mm)					WEIGHT (kg)
	kW	HP	B1	B2	B1+B2	D1	D2	
XR(L) 5-2	0.75	1	366.5	255	621.5	170	160	21
XR(L) 5-4	1.5	2	420.5	315	735.5	187	170	27
XR(L) 5-5	1.5	2	447.5	315	762.5	187	170	34
XR(L) 5-7	2.2	3	501.5	315	816.5	187	170	35
XR(L) 5-9	2.2	3	555.5	315	870.5	187	170	37
XR(L) 5-12	3.7	5	636.5	330	966.5	227	220	45
XR(L) 5-14	3.7	5	690.5	330	1020.5	227	220	55
XR(L) 5-16	3.7	5	744.5	330	1074.5	227	220	56
XR(L) 5-20	5.5	7.5	882.5	365	1247.5	268	245	72
XR(L) 5-22	5.5	7.5	936.5	365	1301.5	268	245	73
XR(L) 5-24	7.5	10	990.5	365	1355.5	268	245	86

Performance Curve

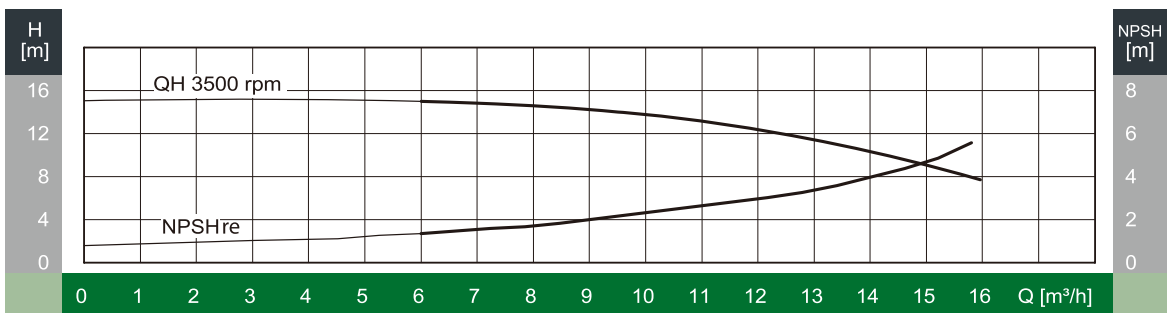
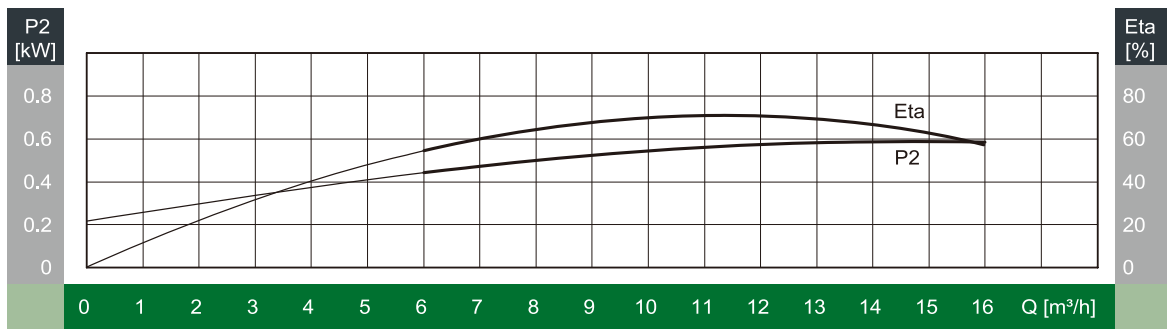
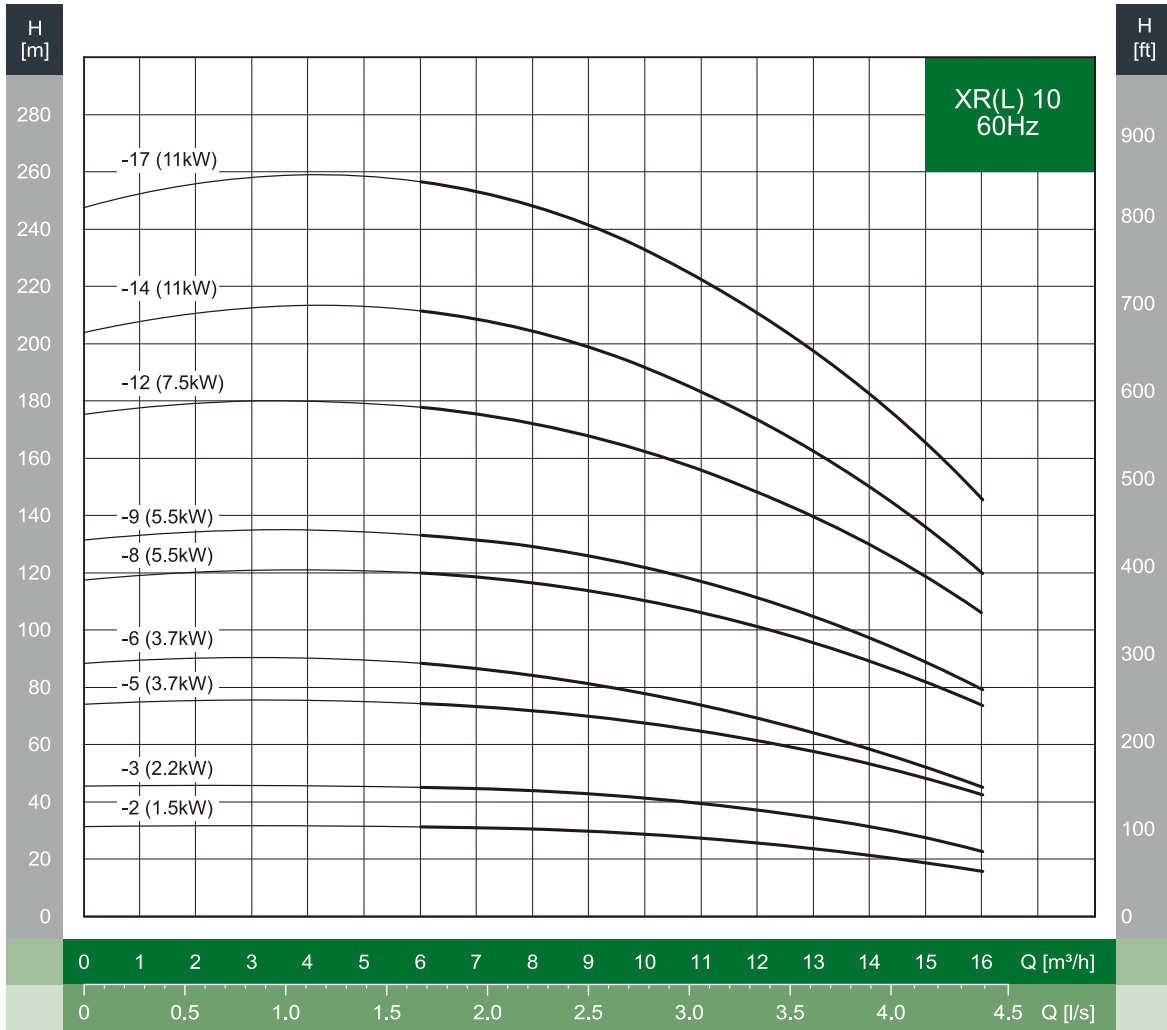

Outline Drawing

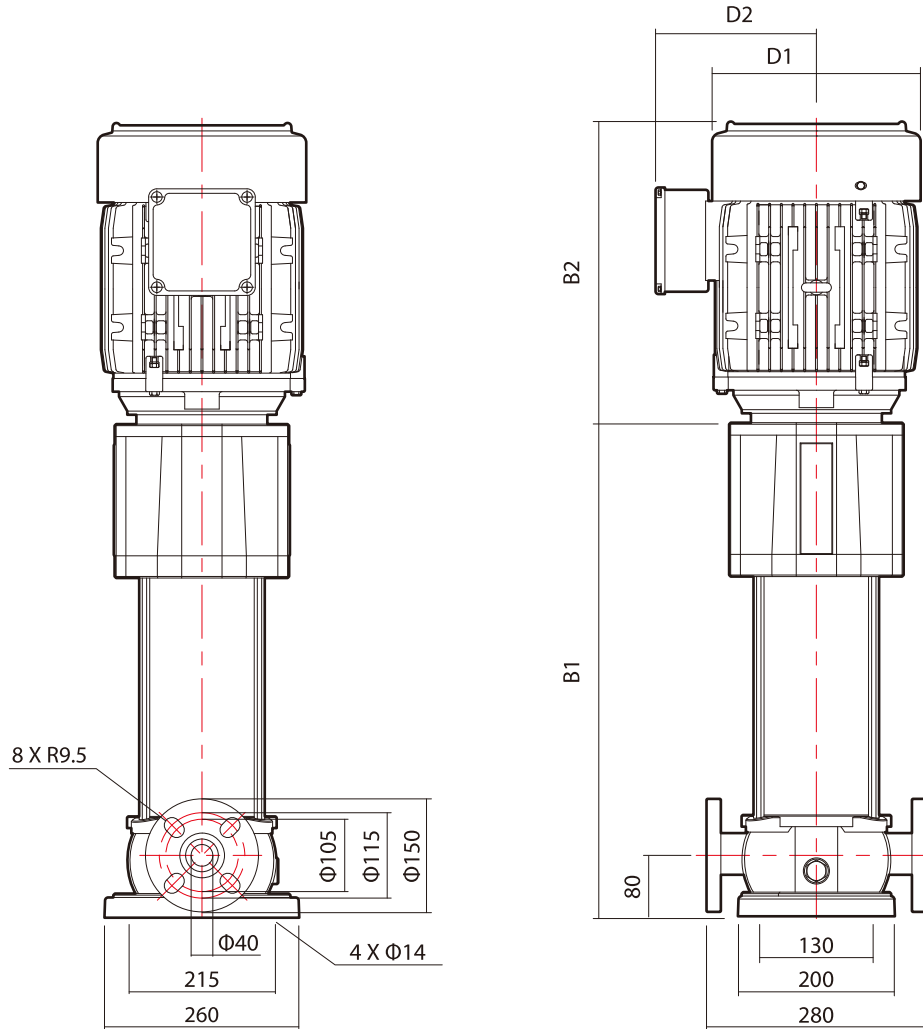

Dimension / Weight

MODEL	POWER		DIMENSION (UNIT: mm)					WEIGHT (kg)
	kW	HP	B1	B2	B1+B2	D1	D2	
XR(L) 10-2	1.5	2	433	315	748	187	170	44
XR(L) 10-3	2.2	3	463	315	778	187	170	45
XR(L) 10-5	3.7	5	523	330	853	227	220	54
XR(L) 10-6	3.7	5	553	330	883	227	220	64
XR(L) 10-8	5.5	7.5	633	365	998	268	245	86
XR(L) 10-9	5.5	7.5	663	365	1028	268	245	87
XR(L) 10-12	7.5	10	753	365	1118	268	245	101
XR(L) 10-14	11	15	843	480	1323	318	290	144
XR(L) 10-17	11	15	933	480	1413	318	290	148

Performance Curve

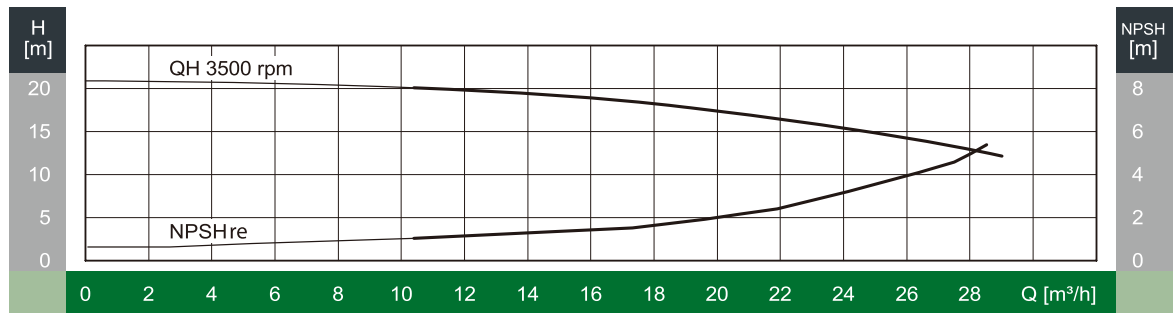
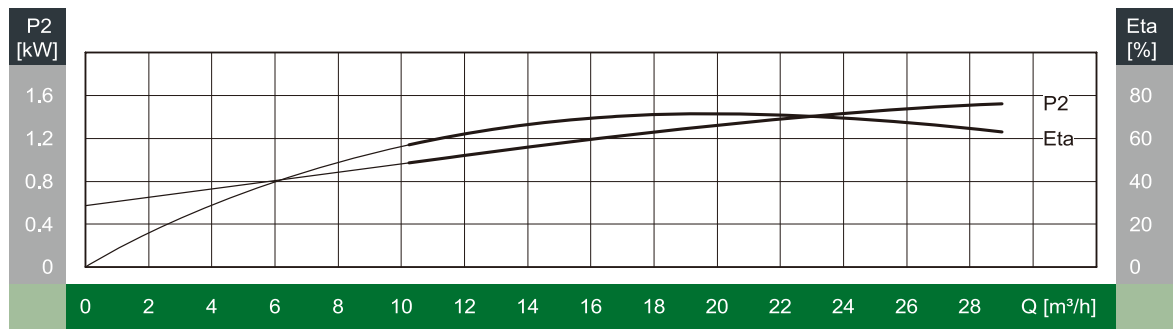
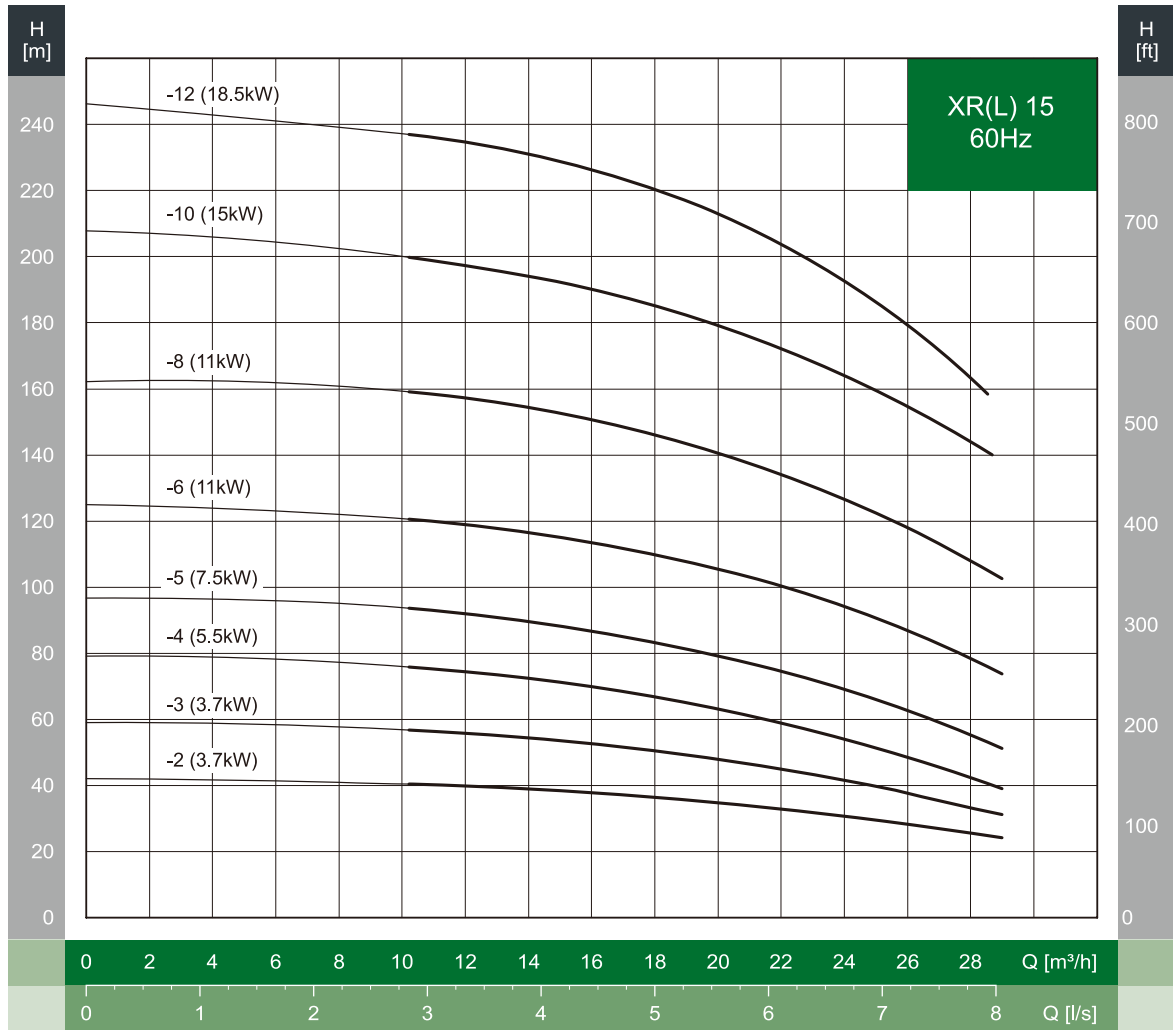

Outline Drawing

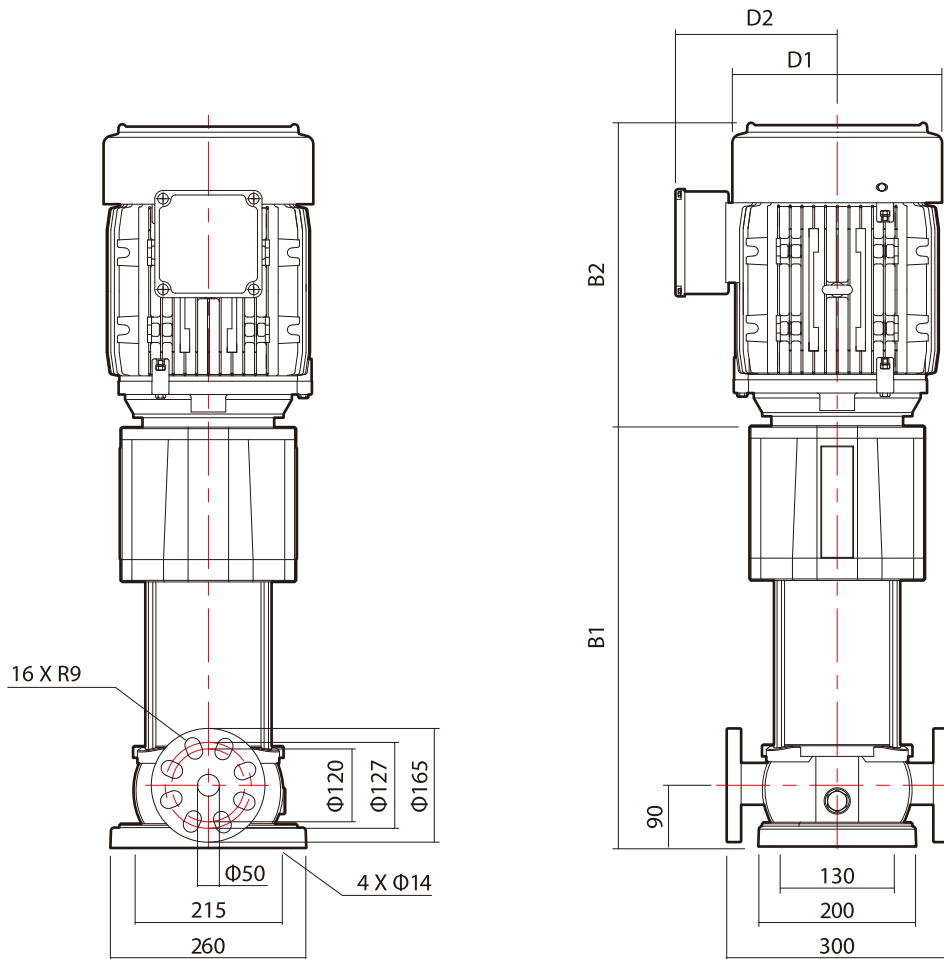

Dimension / Weight

MODEL	POWER		DIMENSION (UNIT: mm)					WEIGHT (kg)
	kW	HP	B1	B2	B1+B2	D1	D2	
XR(L) 15-2	3.7	5	478	330	808	227	220	53
XR(L) 15-3	3.7	5	523	330	853	227	220	64
XR(L) 15-4	5.5	7.5	588	365	953	268	245	86
XR(L) 15-5	7.5	10	633	365	998	268	245	99
XR(L) 15-6	11	15	708	480	1188	318	290	141
XR(L) 15-8	11	15	798	480	1278	318	290	144
XR(L) 15-10	15	20	888	480	1368	318	290	160
XR(L) 15-12	18.5	25	978	525	1503	318	290	176

Performance Curve

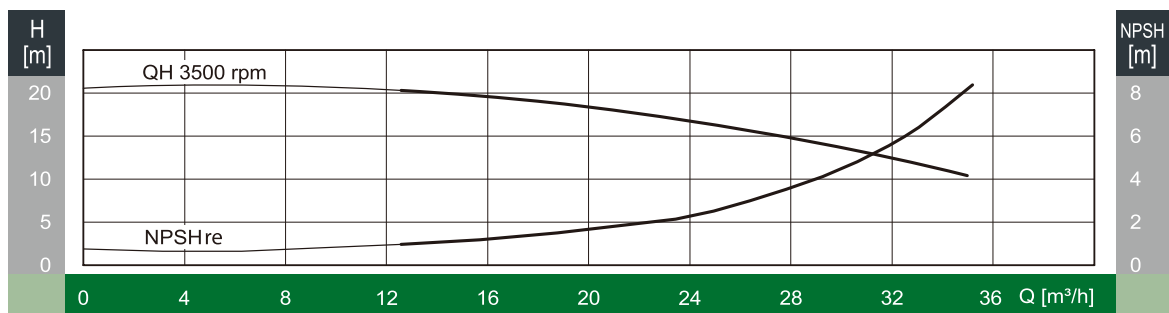
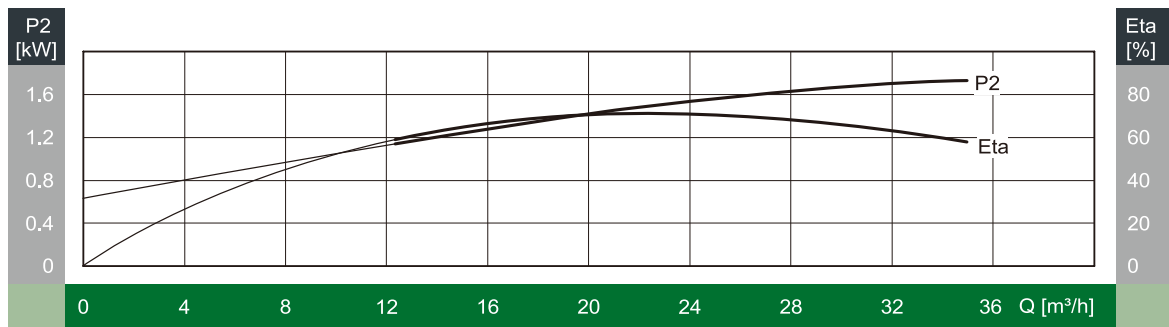
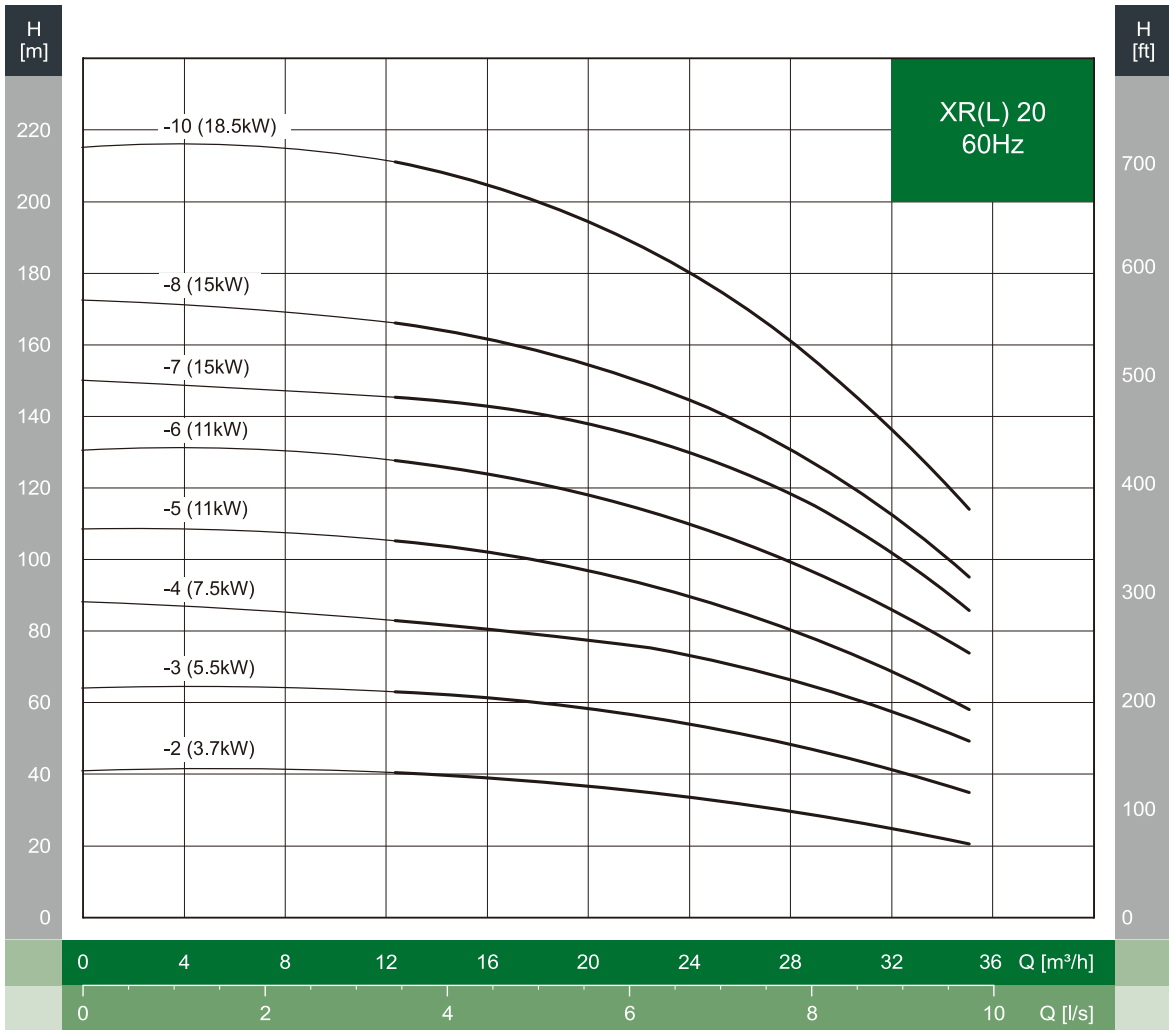

Outline Drawing

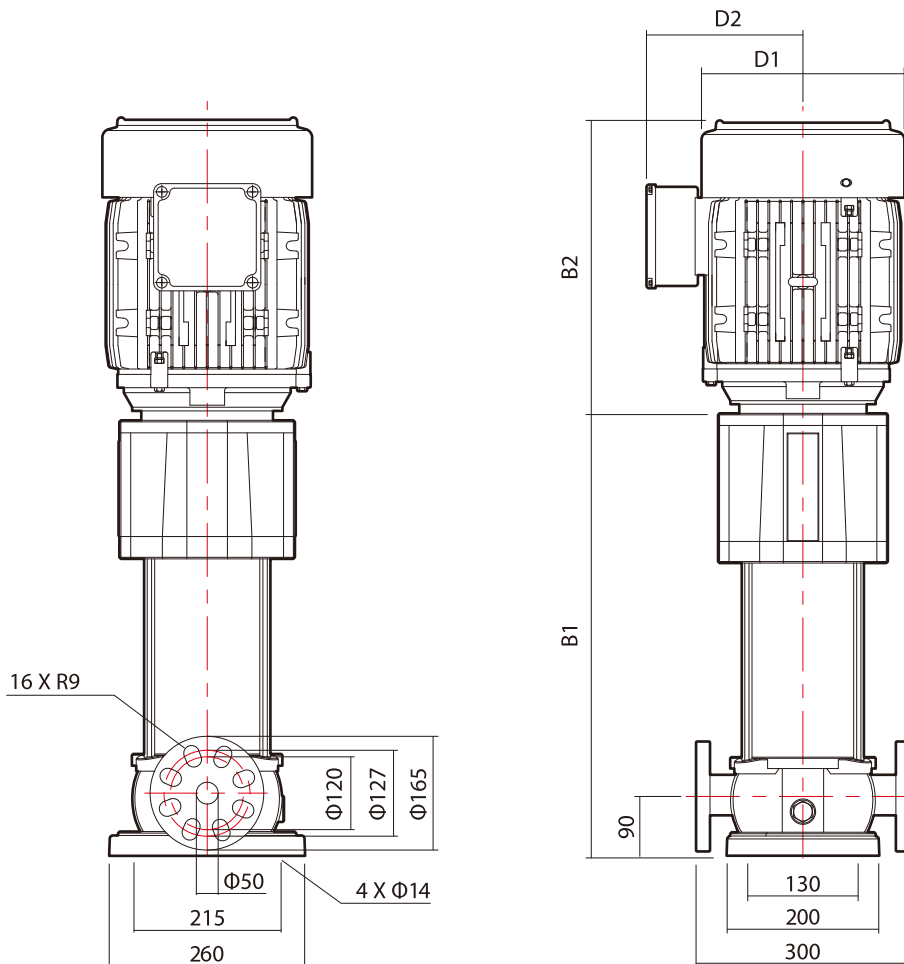

Dimension / Weight

MODEL	POWER		DIMENSION (UNIT: mm)					WEIGHT (kg)
	kW	HP	B1	B2	B1+B2	D1	D2	
XR(L) 20-2	3.7	5	478	330	808	227	220	62
XR(L) 20-3	5.5	7.5	543	365	908	268	245	84
XR(L) 20-4	7.5	10	588	365	953	268	245	98
XR(L) 20-5	11	15	663	480	1143	318	290	139
XR(L) 20-6	11	15	708	480	1188	318	290	141
XR(L) 20-7	15	20	753	480	1233	318	290	155
XR(L) 20-8	15	20	798	480	1278	318	290	156
XR(L) 20-10	18.5	25	888	525	1413	318	290	173

Performance Curve

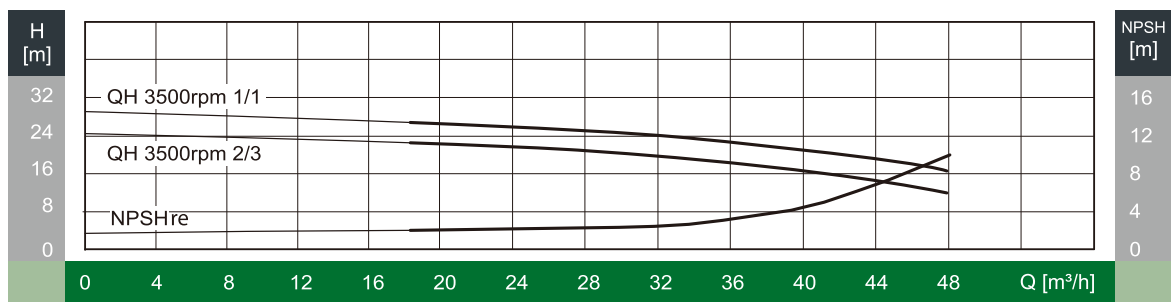
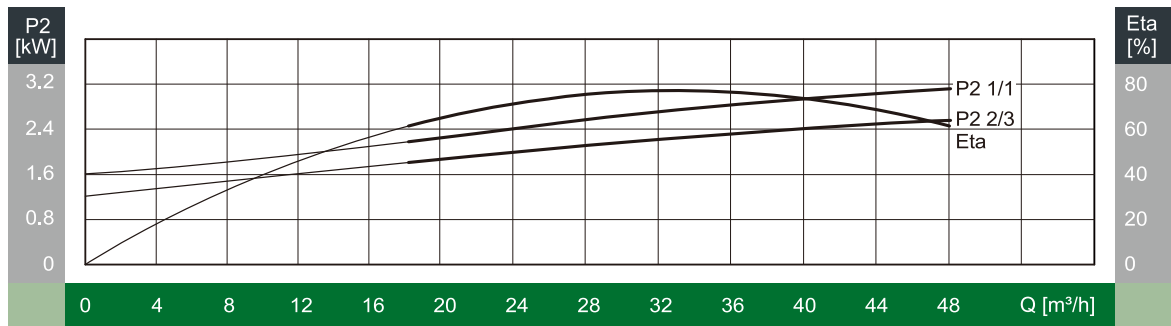
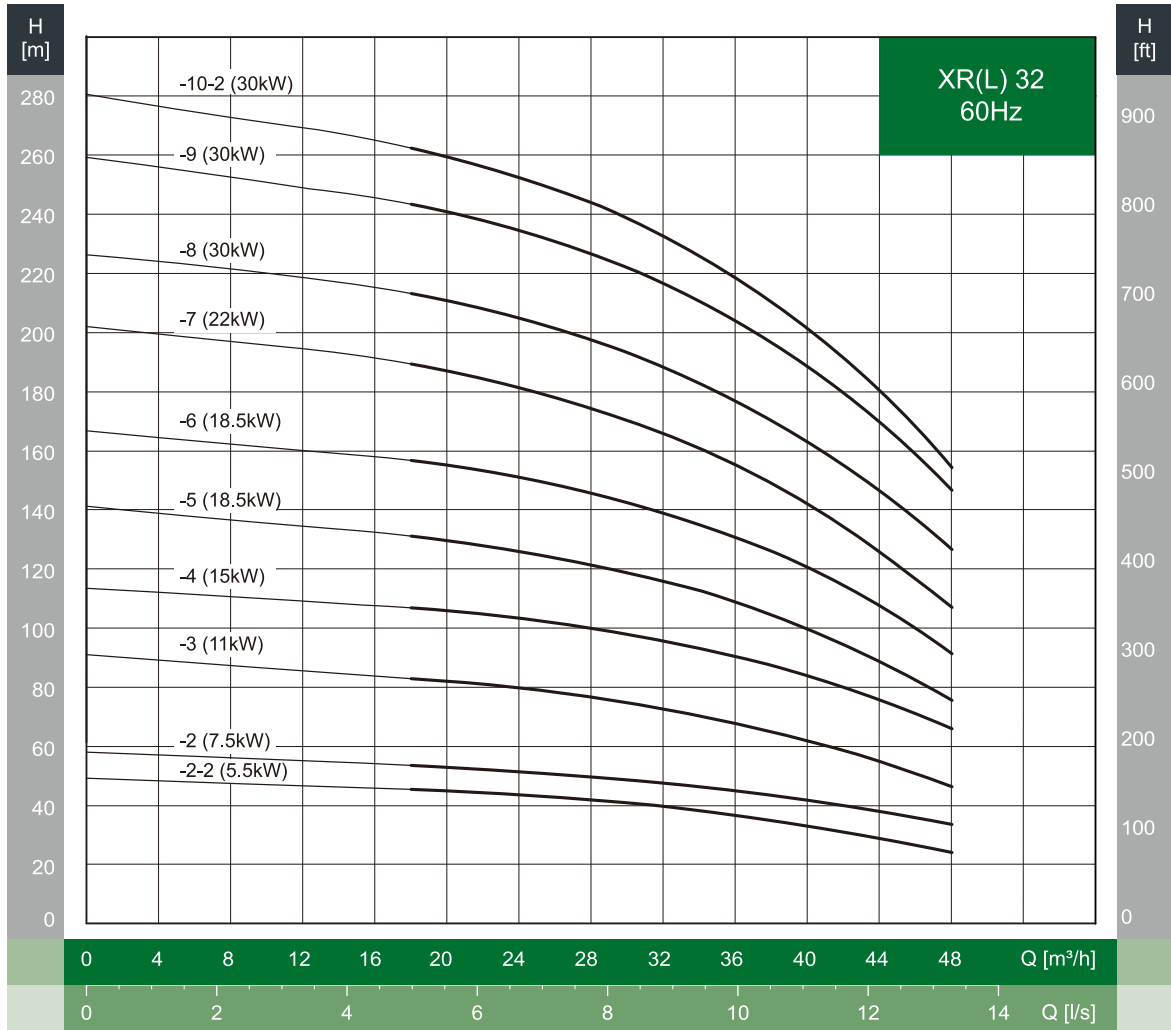

Outline Drawing

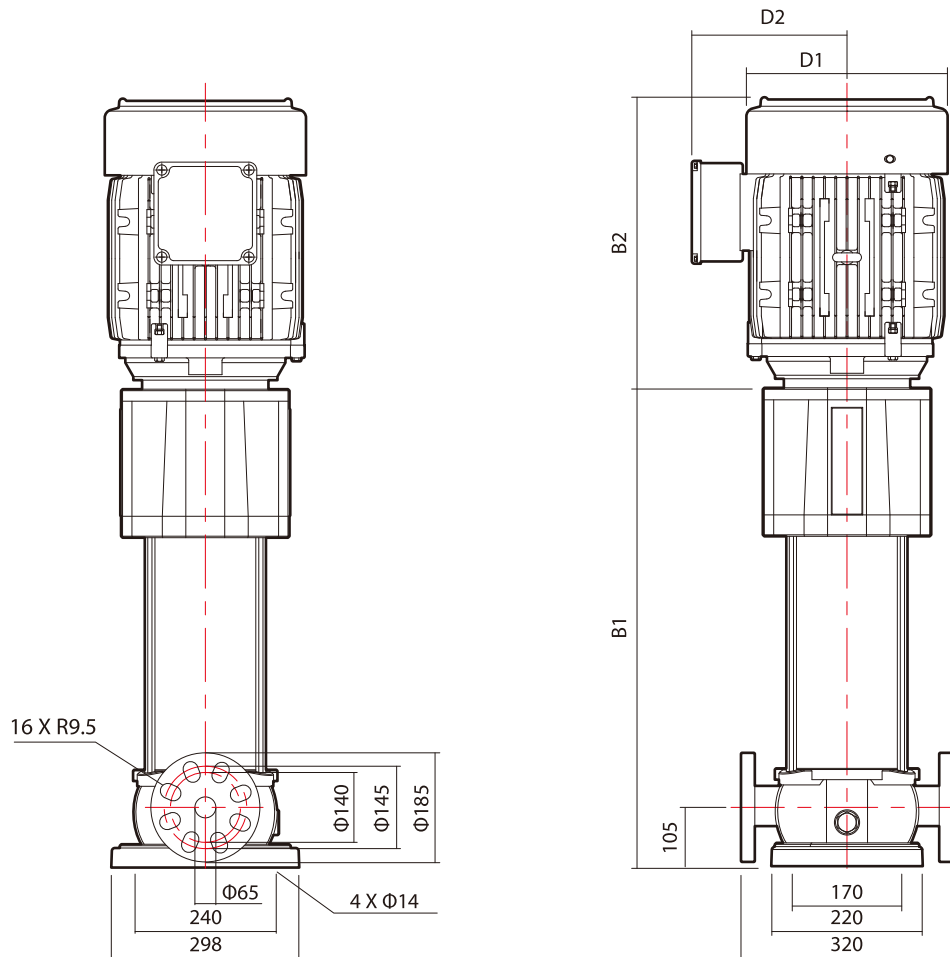

Dimension / Weight

MODEL	POWER		DIMENSION (UNIT: mm)					WEIGHT (kg)
	kW	HP	B1	B2	B1+B2	D1	D2	
XR(L) 32-2-2	5.5	7.5	644.5	365	1009.5	268	245	95
XR(L) 32-2	7.5	10	644.5	365	1009.5	268	245	107
XR(L) 32-3	11	15	744.5	480	1224.5	318	290	154
XR(L) 32-4	15	20	814.5	480	1294.5	318	290	170
XR(L) 32-5	18.5	25	884.5	525	1409.5	318	290	186
XR(L) 32-6	18.5	25	954.5	525	1479.5	318	290	189
XR(L) 32-7	22	30	1024.5	570	1594.5	354	305	206
XR(L) 32-8	30	40	1094.5	610	1704.5	354	305	314
XR(L) 32-9	30	40	1164.5	610	1774.5	354	305	318
XR(L) 32-10-2	30	40	1234.5	610	1844.5	354	305	321

Performance Curve

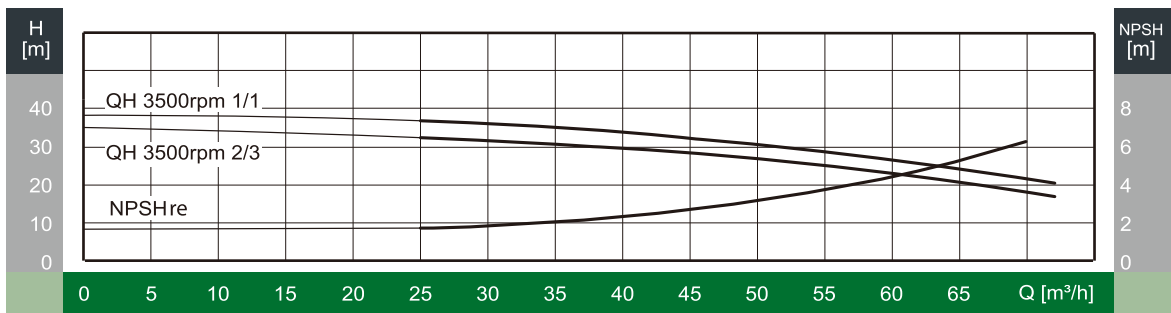
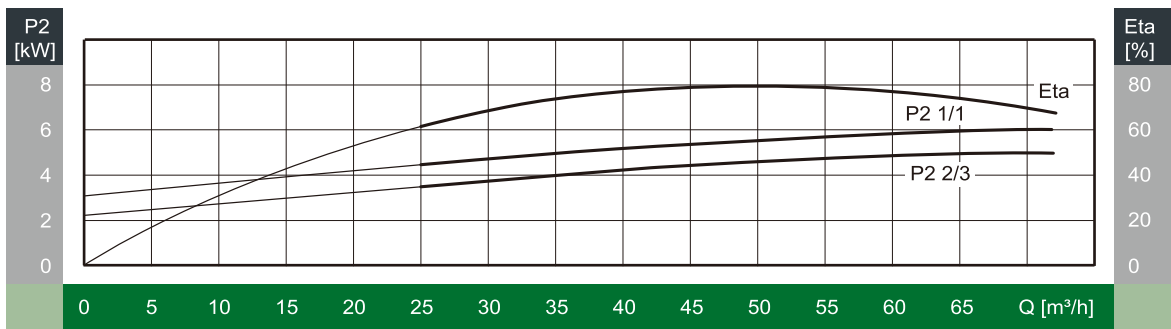
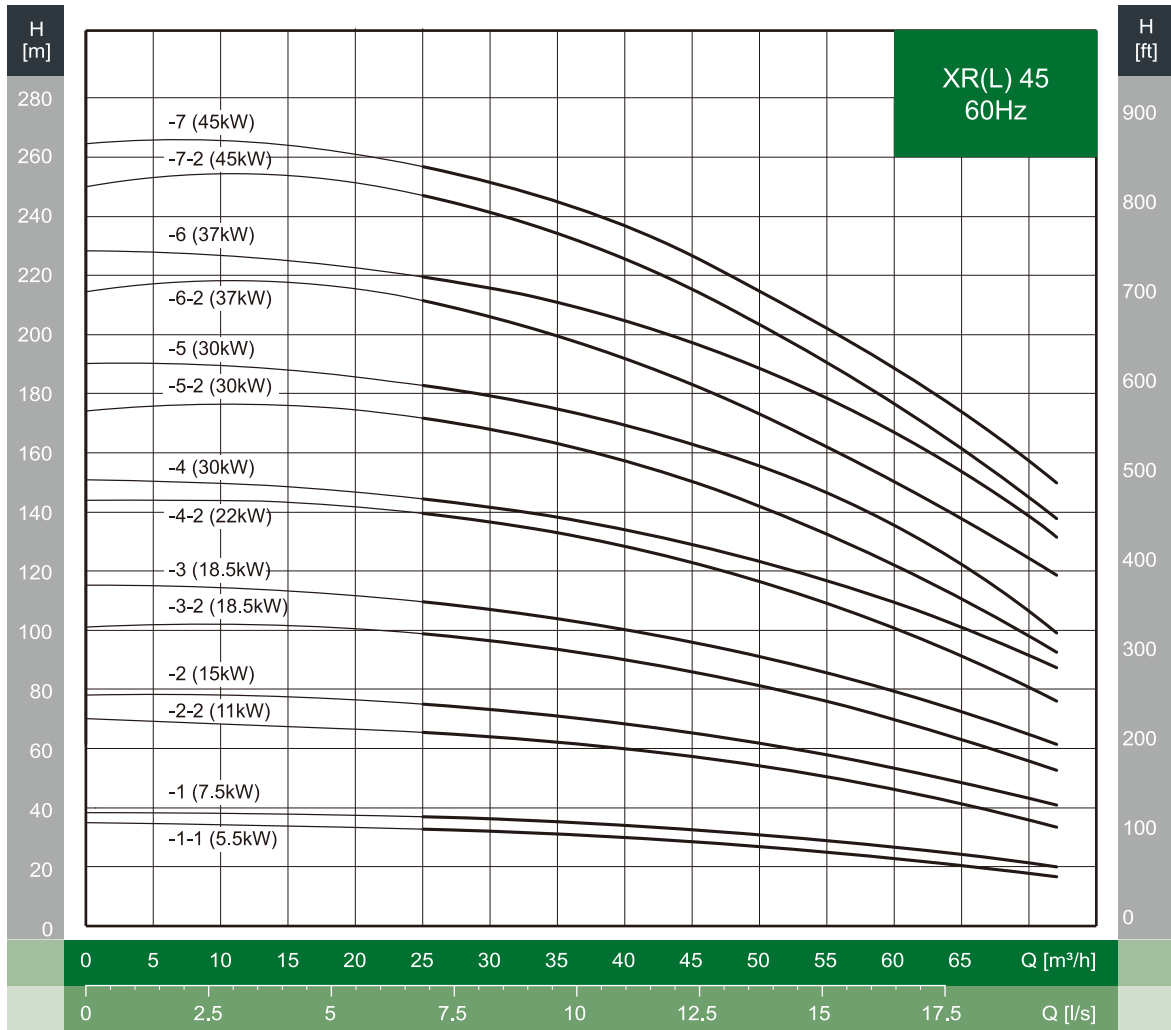

Outline Drawing

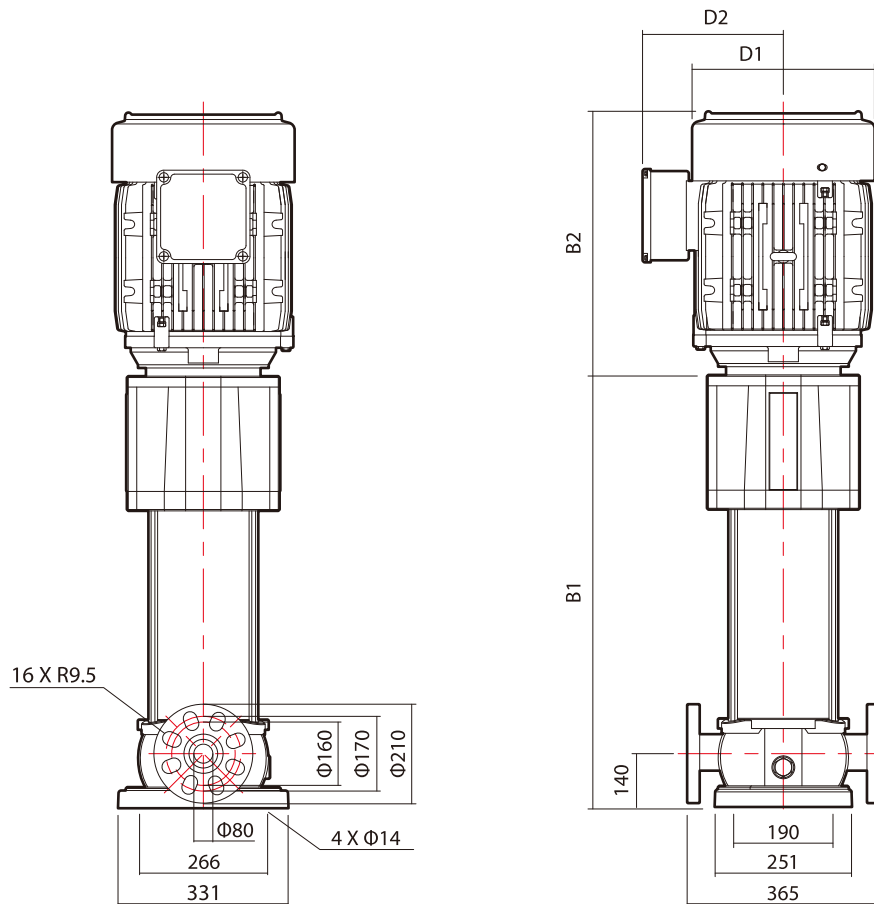

Dimension / Weight

MODEL	POWER		DIMENSION (UNIT: mm)					WEIGHT (kg)
	kW	HP	B1	B2	B1+B2	D1	D2	
XR(L) 45-1-1	5.5	7.5	631.5	365	996.5	268	245	100
XR(L) 45-1	7.5	10	631.5	365	996.5	268	245	112
XR(L) 45-2-2	11	15	741.5	480	1221.5	318	290	160
XR(L) 45-2	15	20	741.5	480	1221.5	318	290	173
XR(L) 45-3-2	18.5	25	821.5	525	1346.5	318	290	190
XR(L) 45-3	18.5	25	821.5	525	1346.5	318	290	190
XR(L) 45-4-2	22	30	901.5	570	1471.5	354	305	207
XR(L) 45-4	30	40	901.5	610	1511.5	354	305	309
XR(L) 45-5-2	30	40	981.5	610	1591.5	354	305	313
XR(L) 45-5	30	40	981.5	610	1591.5	354	305	313
XR(L) 45-6-2	37	50	1061.5	670	1731.5	404	350	350
XR(L) 45-6	37	50	1061.5	670	1731.5	404	350	350
XR(L) 45-7-2	45	60	1141.5	670	1811.5	404	350	438
XR(L) 45-7	45	60	1141.5	670	1811.5	404	350	438

Performance Curve

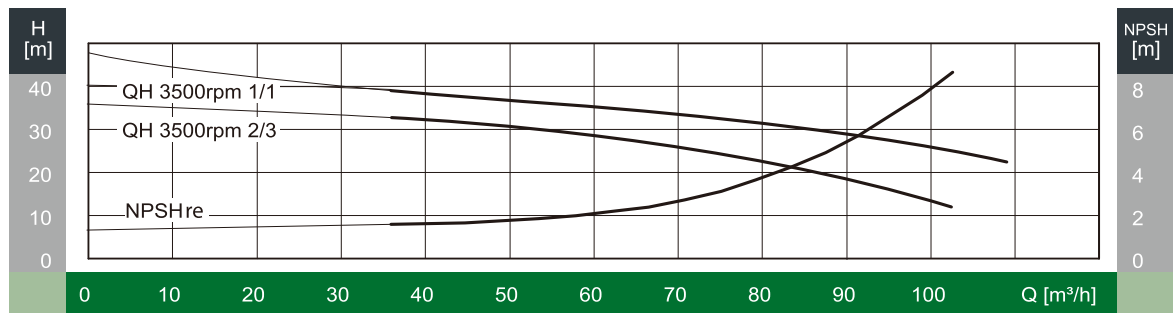
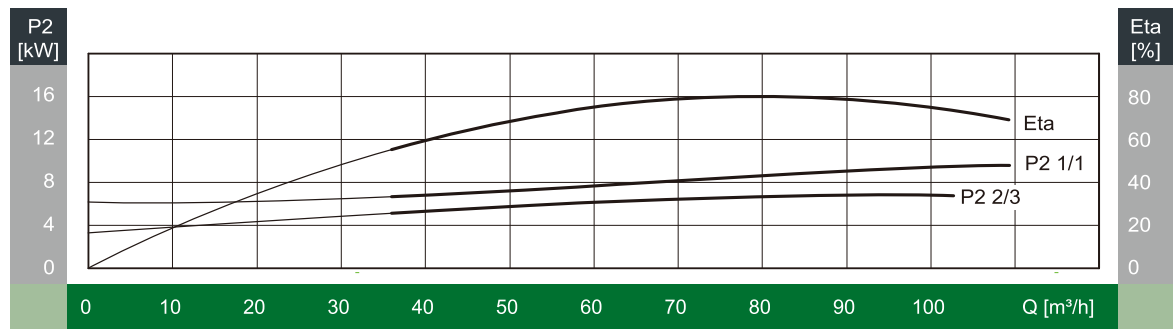
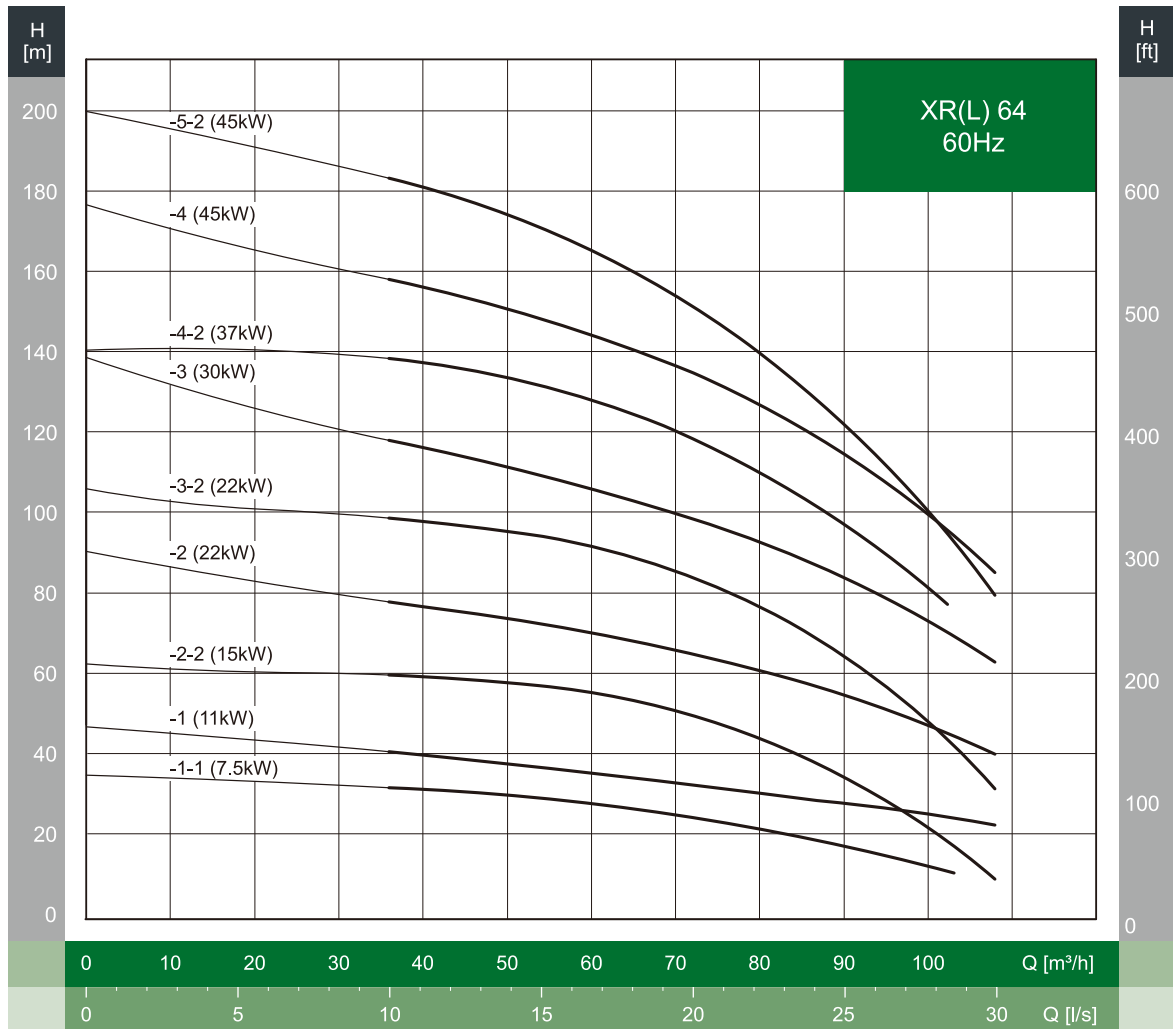

Outline Drawing

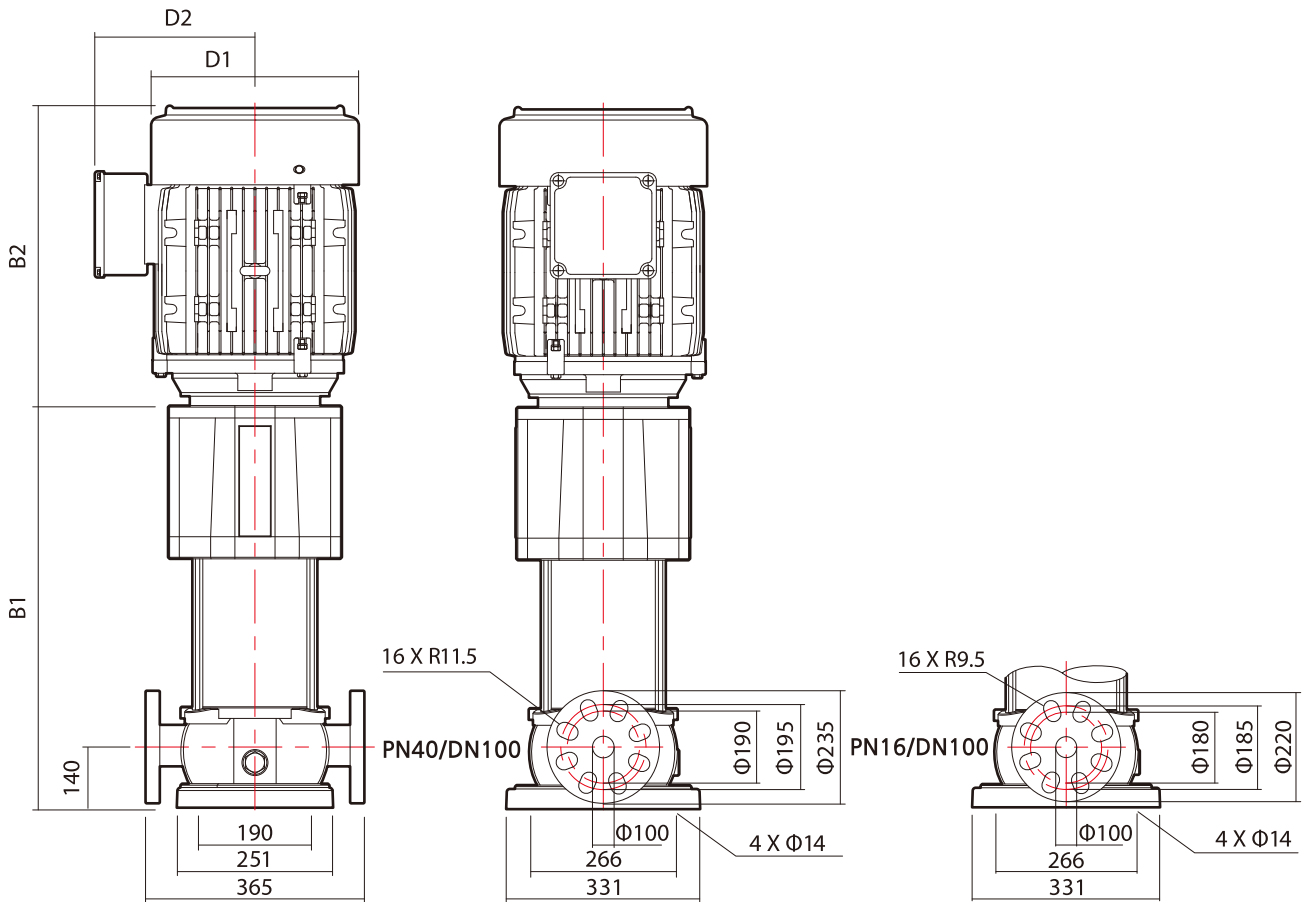

XR(L)64-3-2 and below models

Dimension / Weight

MODEL	POWER		DIMENSION (UNIT: mm)					WEIGHT (kg)
	kW	HP	B1	B2	B1+B2	D1	D2	
XR(L) 64-1-1	7.5	10	634	365	999	268	245	114
XR(L) 64-1	11	15	664	480	1144	318	290	158
XR(L) 64-2-2	15	20	746.5	480	1226.5	318	290	175
XR(L) 64-2	22	30	746.5	570	1316.5	354	305	202
XR(L) 64-3-2	22	30	829	570	1399	354	305	206
XR(L) 64-3	30	40	829	610	1439	354	305	309
XR(L) 64-4-2	37	50	911.5	670	1581.5	404	350	346
XR(L) 64-4	45	60	911.5	670	1581.5	404	350	430
XR(L) 64-5-2	45	60	994	670	1664	404	350	435

Performance Curve

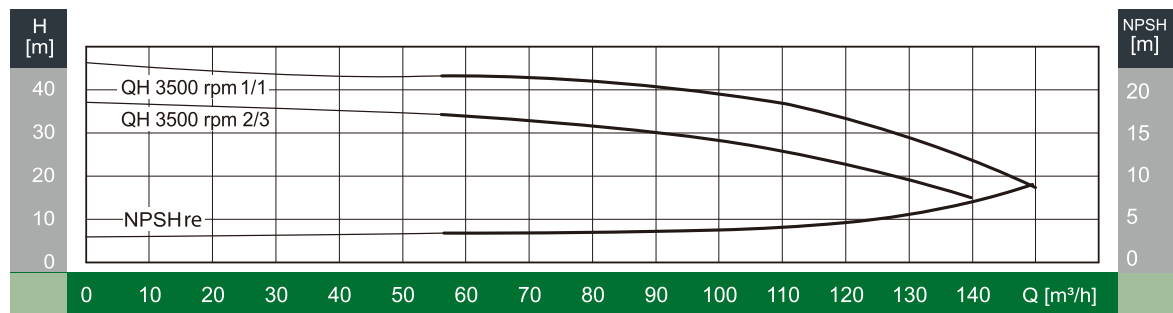
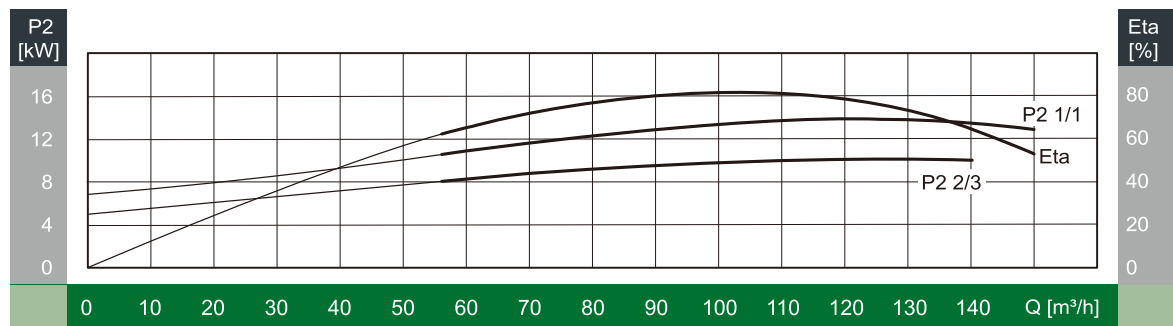
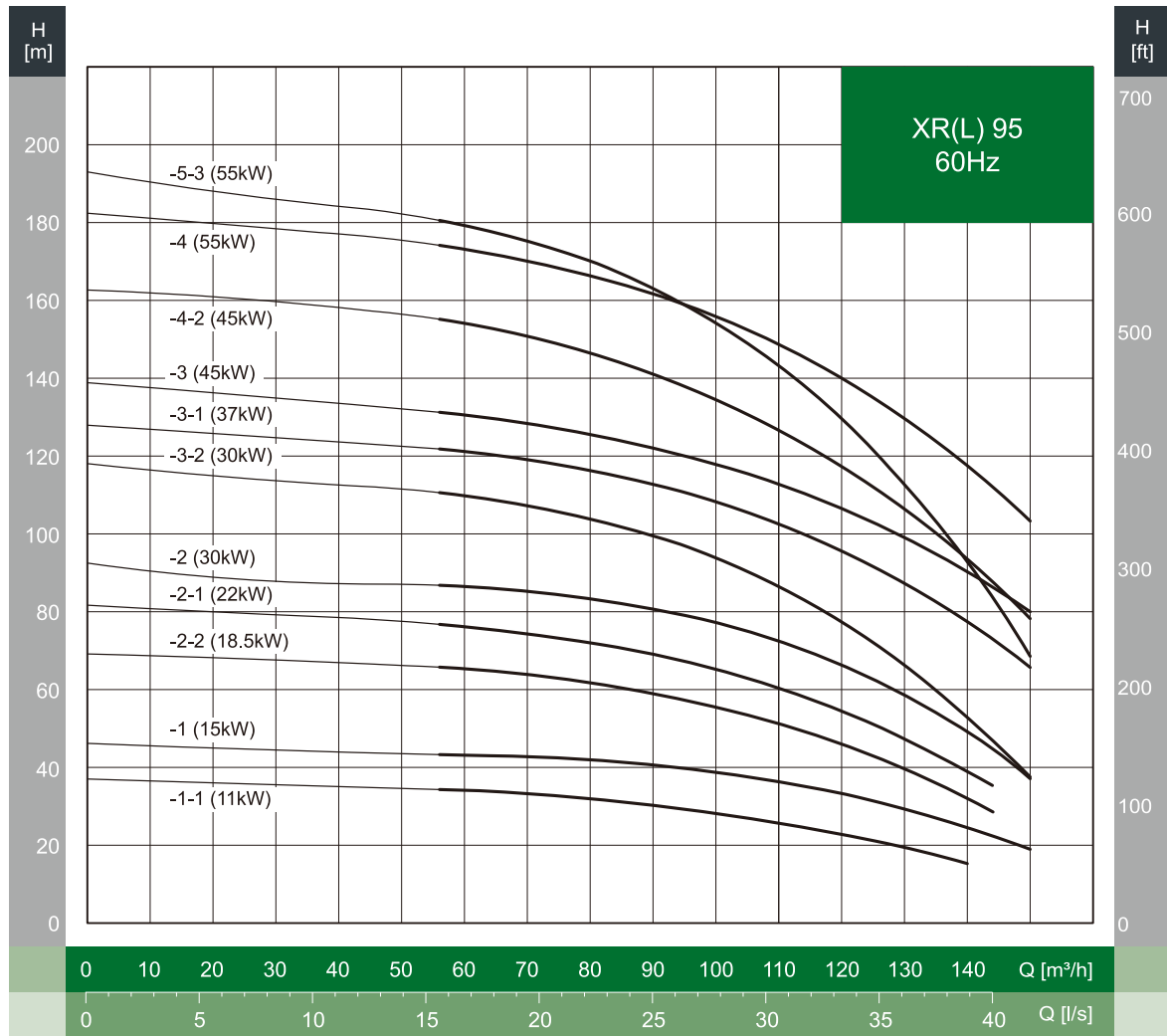

Outline Drawing

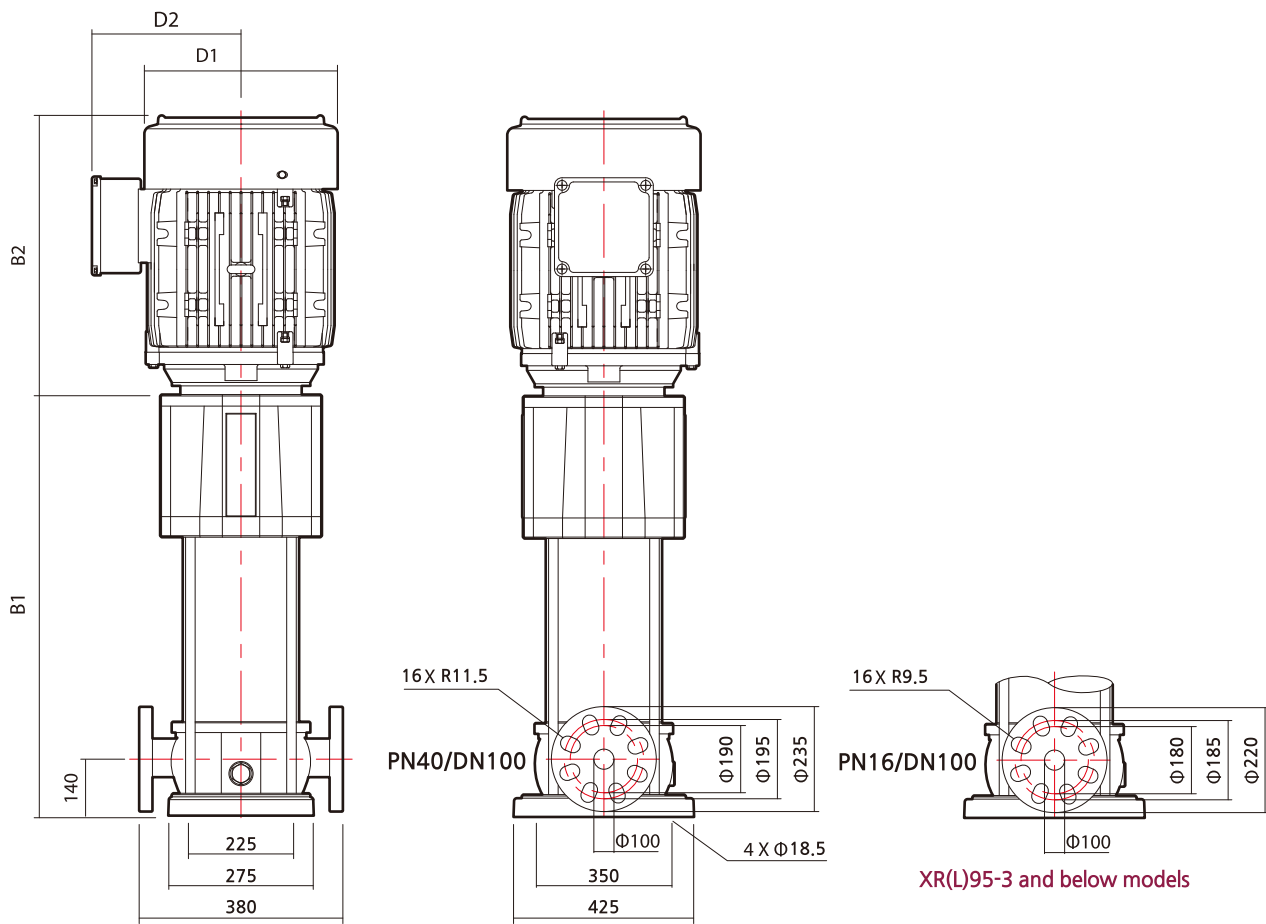

Dimension / Weight

MODEL	POWER		DIMENSION (UNIT: mm)					WEIGHT (kg)
	kW	HP	B1	B2	B1+B2	D1	D2	
XR(L) 95-1-1	11	15	701	480	1181	318	290	189
XR(L) 95-1	15	20	701	480	1181	318	290	189
XR(L) 95-2-2	18.5	25	806	525	1331	318	290	210
XR(L) 95-2-1	22	30	806	570	1376	354	305	225
XR(L) 95-2	30	40	806	610	1416	354	305	345
XR(L) 95-3-2	30	40	910	610	1520	354	305	350
XR(L) 95-3-1	37	50	910	670	1580	404	350	375
XR(L) 95-3	45	60	910	670	1580	404	350	457
XR(L) 95-4-2	45	60	1015	670	1685	404	350	462
XR(L) 95-4	55	75	1035	685	1720	457	460	540
XR(L) 95-5-3	55	75	1139	685	1824	457	460	552

Performance Curve

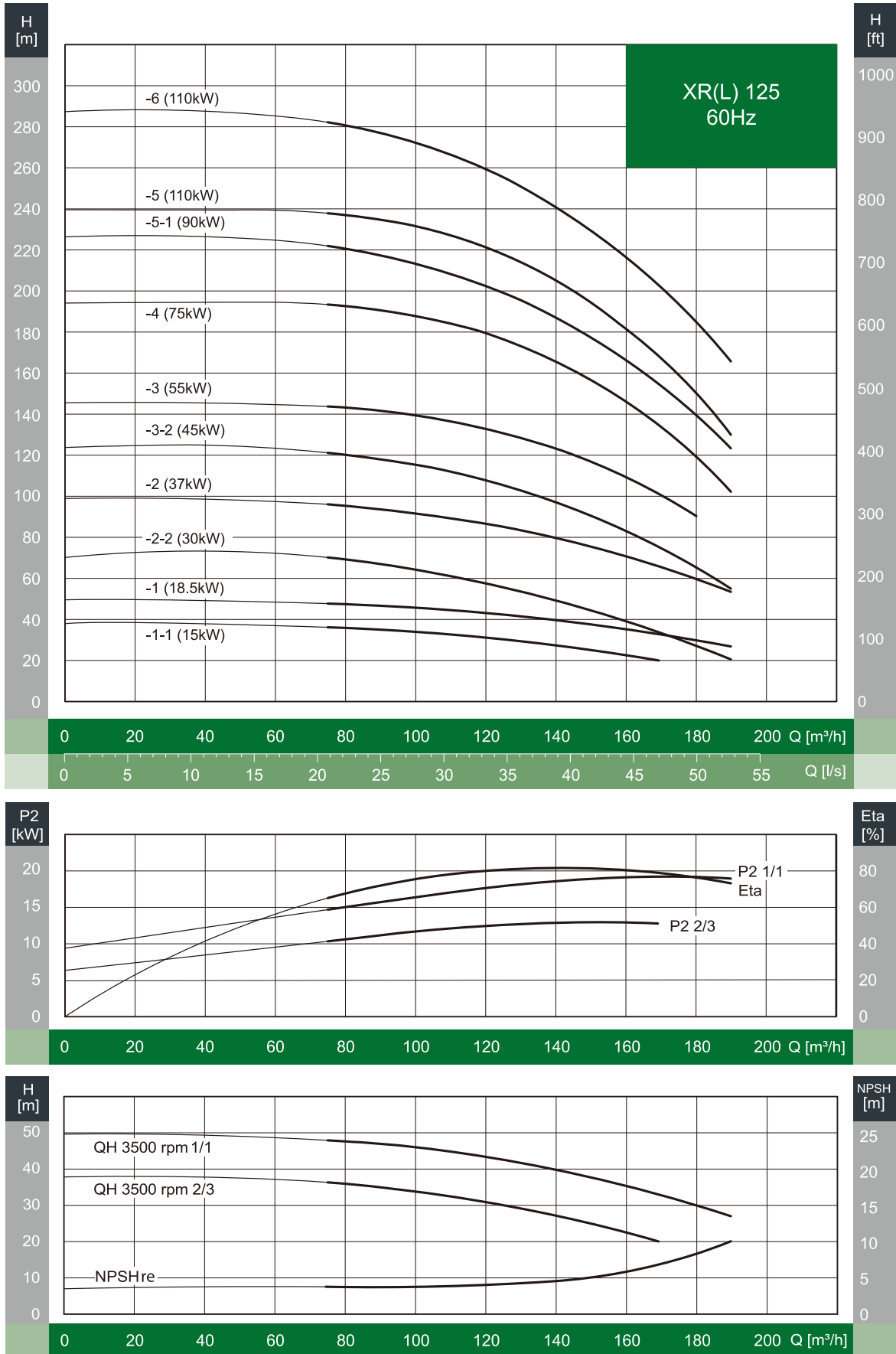

Outline Drawing

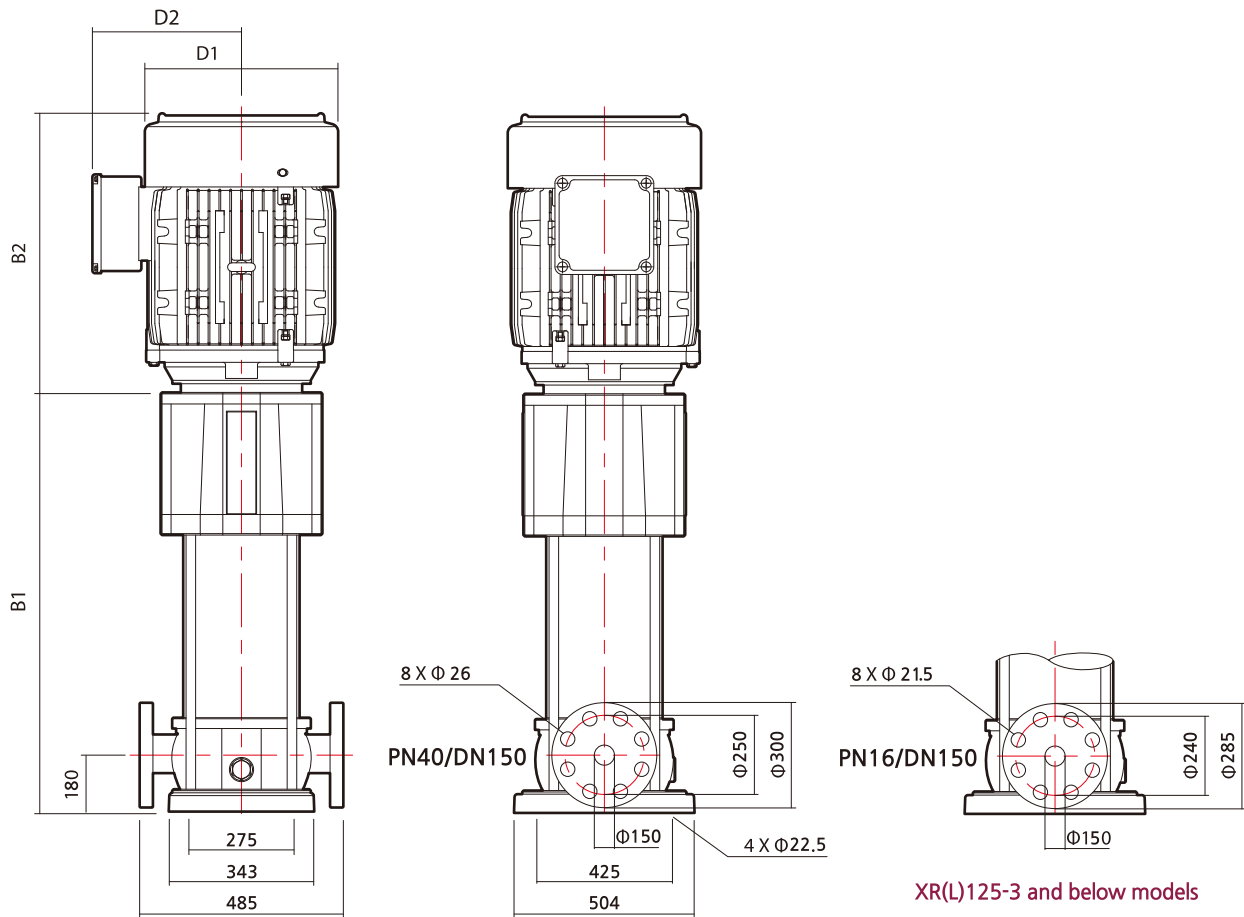

XR(L)125-3 and below models

Dimension / Weight

MODEL	POWER		DIMENSION (UNIT: mm)					WEIGHT (kg)
	kW	HP	B1	B2	B1+B2	D1	D2	
XR(L) 125-1-1	15	20	783	480	1263	318	290	265
XR(L) 125-1	18.5	25	783	525	1308	318	290	282
XR(L) 125-2-2	30	40	905	610	1515	354	305	387
XR(L) 125-2	37	50	905	670	1575	404	350	410
XR(L) 125-3-2	45	60	1057	670	1727	404	350	500
XR(L) 125-3	55	75	1057	685	1742	457	460	585
XR(L) 125-4	75	100	1179	760	1939	512	480	705
XR(L) 125-5-1	90	120	1301	800	2101	512	480	803
XR(L) 125-5	110	150	1311	950	2261	550	505	992
XR(L) 125-6	110	150	1433	950	2383	550	505	997

Performance Curve

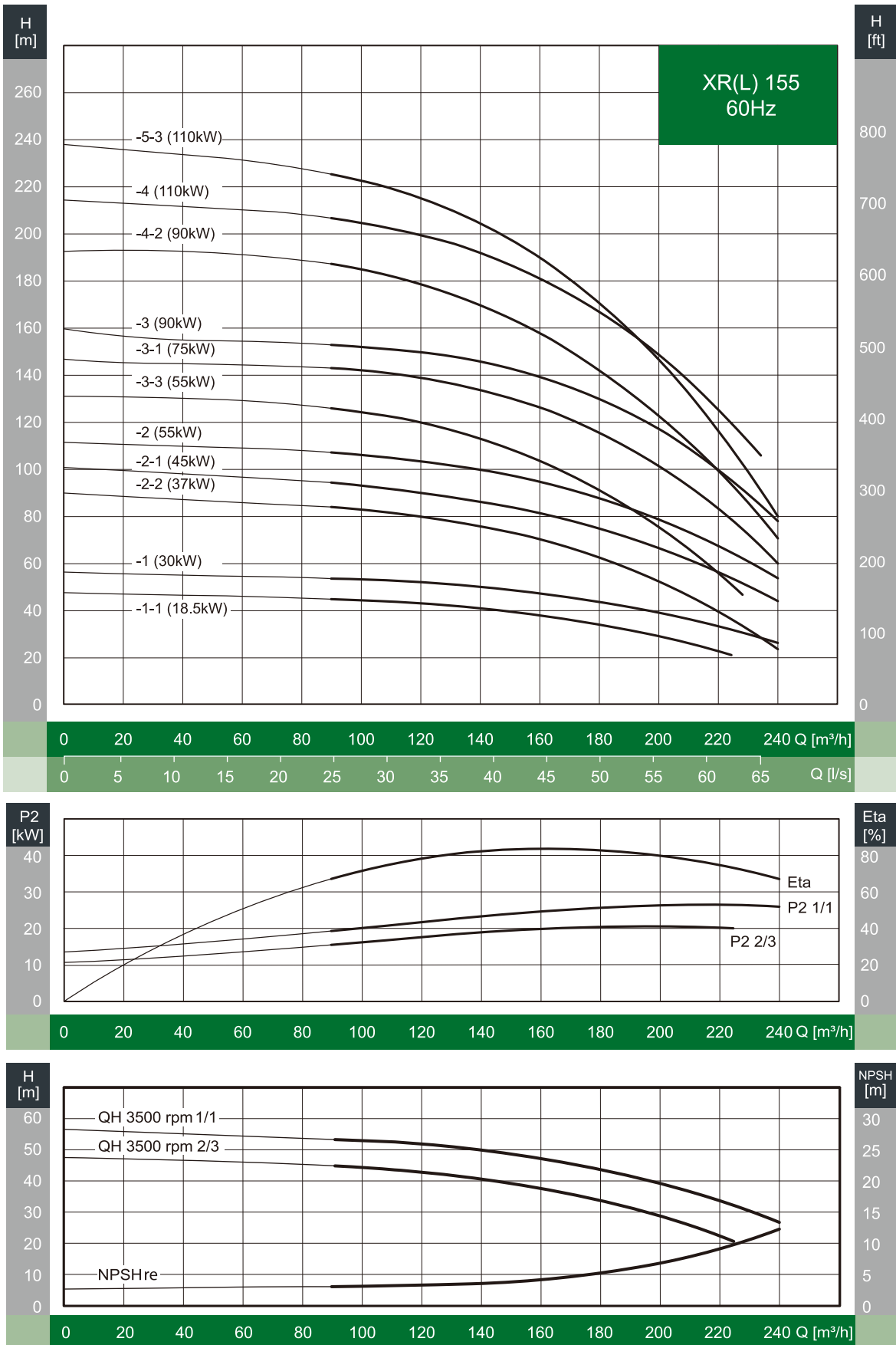

Outline Drawing

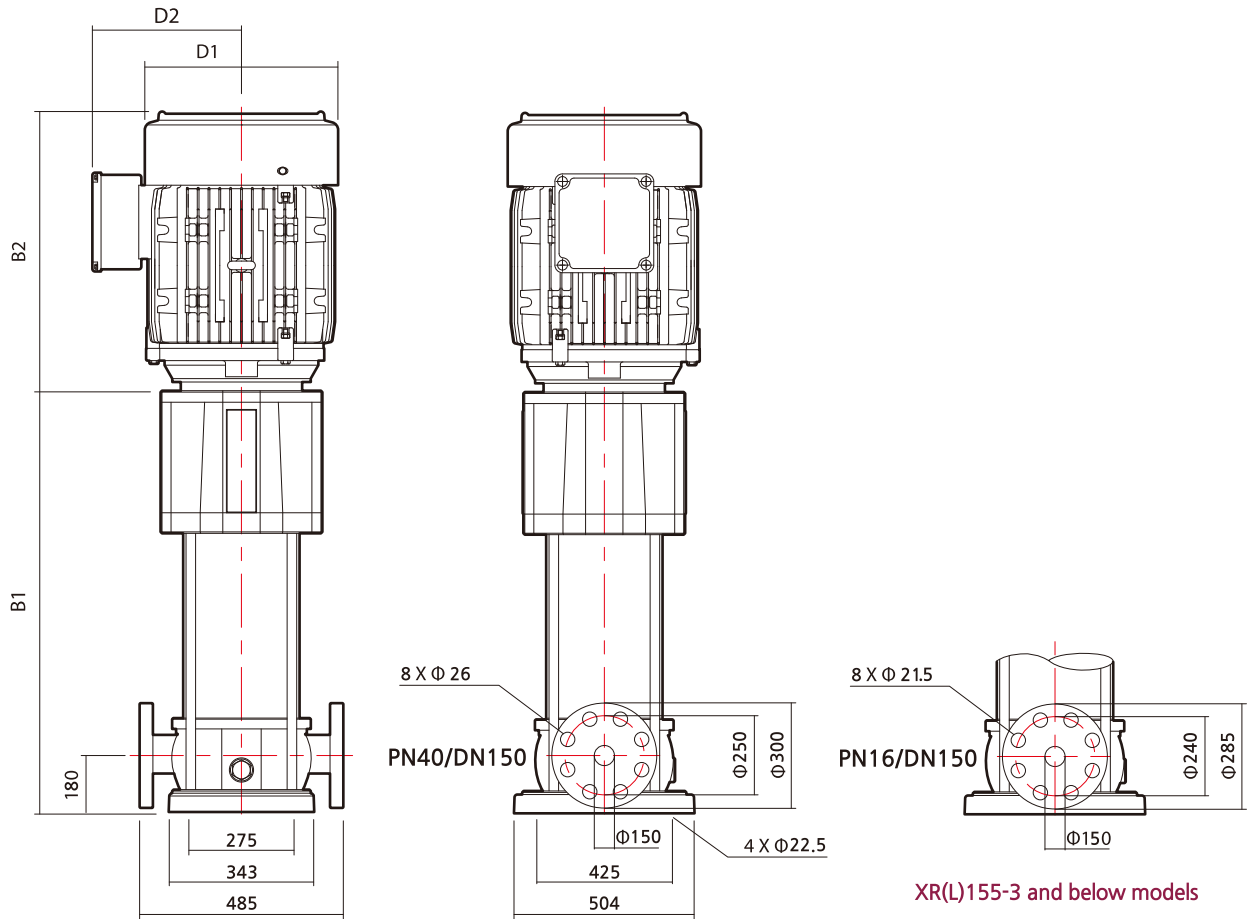

Dimension / Weight

MODEL	POWER		DIMENSION (UNIT: mm)					WEIGHT (kg)
	kW	HP	B1	B2	B1+B2	D1	D2	
XR(L) 155-1-1	18.5	25	783	525	1308	318	290	218
XR(L) 155-1	30	40	783	610	1393	354	305	272
XR(L) 155-2-2	37	50	905	670	1575	404	350	410
XR(L) 155-2-1	45	60	935	670	1605	404	350	490
XR(L) 155-2	55	75	935	685	1620	457	460	585
XR(L) 155-3-3	55	75	1057	685	1742	457	460	590
XR(L) 155-3-1	75	100	1057	760	1817	512	480	702
XR(L) 155-3	90	120	1057	800	1857	512	480	792
XR(L) 155-4-2	90	120	1179	800	1979	512	480	797
XR(L) 155-4	110	150	1189	950	2139	550	505	987
XR(L) 155-5-3	110	150	1311	950	2261	550	505	992

Performance Curve

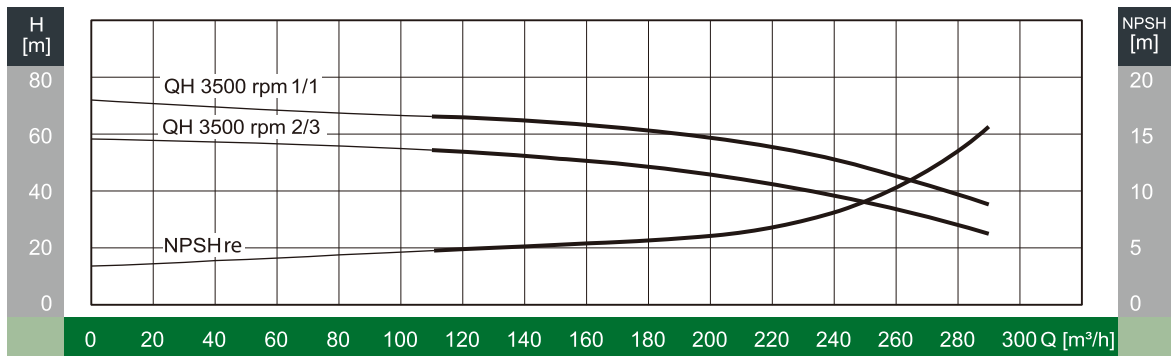
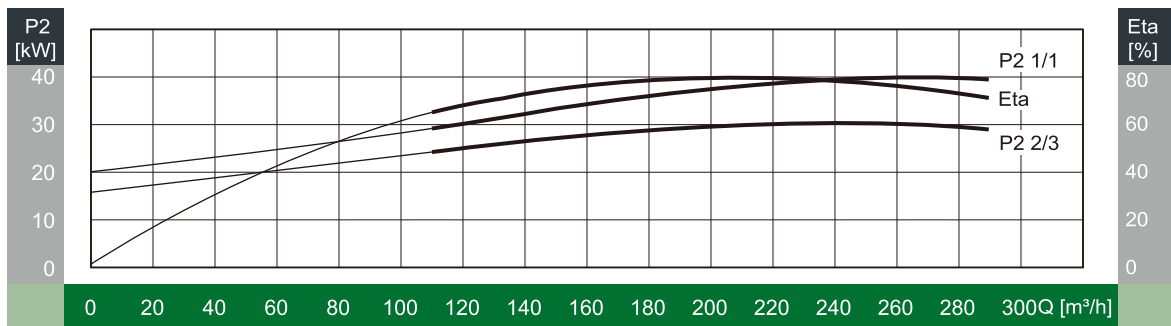
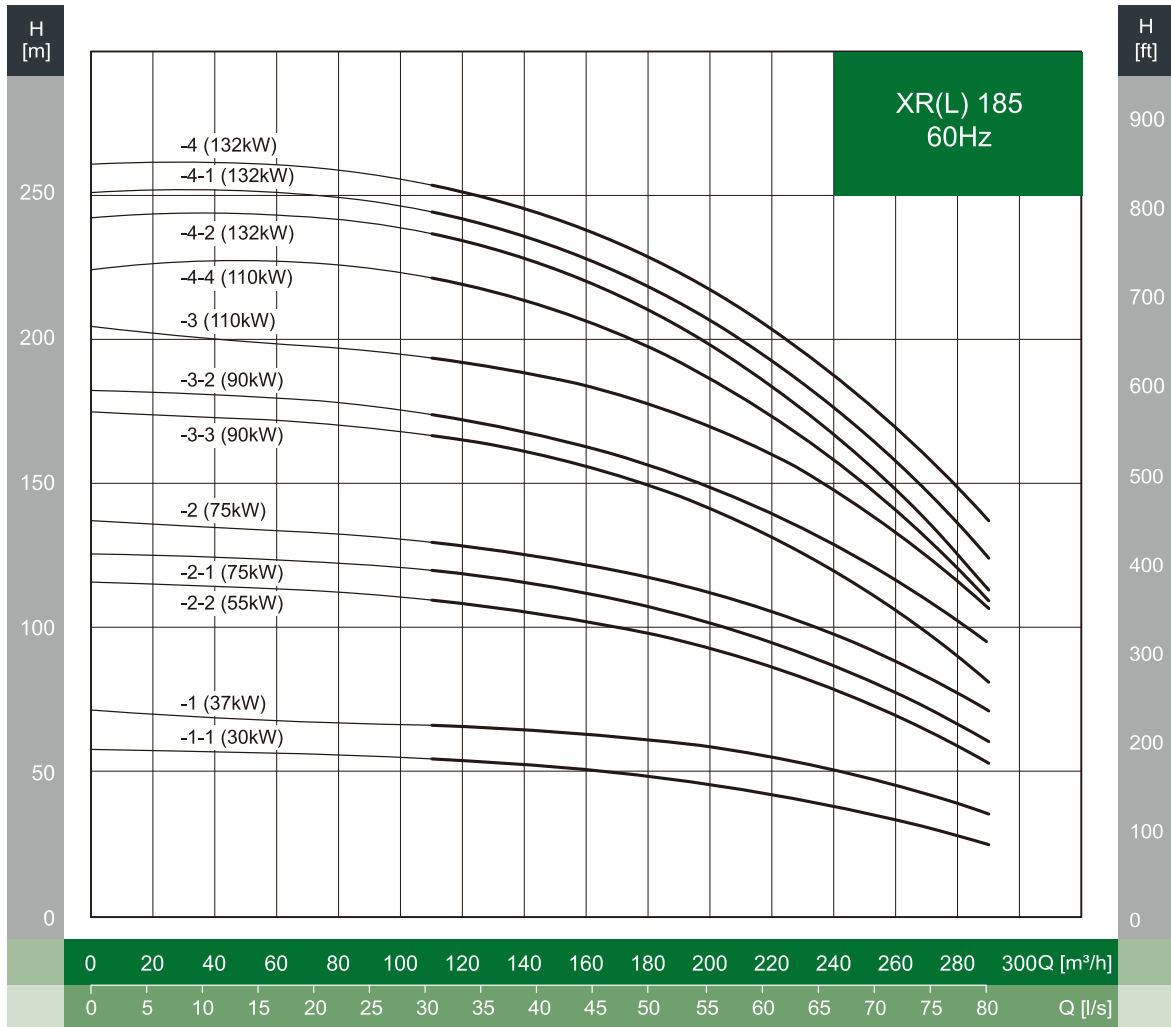

Outline Drawing

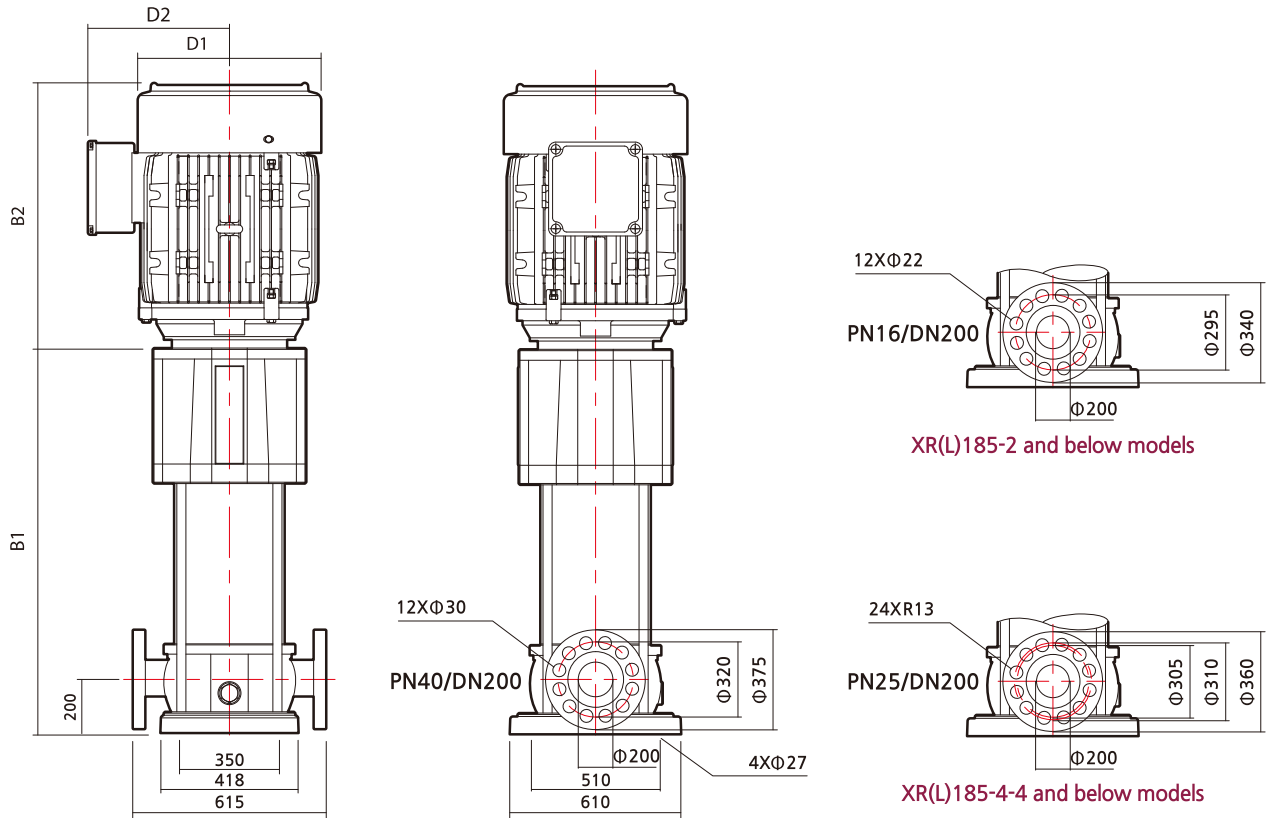

Dimension / Weight

MODEL	POWER		DIMENSION (UNIT: mm)					WEIGHT (kg)
	kW	HP	B1	B2	B1+B2	D1	D2	
XR(L) 185-1-1	30	40	868	610	1478	354	305	415
XR(L) 185-1	37	50	868	670	1538	404	350	548
XR(L) 185-2-2	55	75	1026	685	1711	457	460	649
XR(L) 185-2-1	75	100	1026	760	1786	512	480	807
XR(L) 185-2	75	100	1026	760	1786	512	480	807
XR(L) 185-3-3	90	120	1154	800	1954	512	480	853
XR(L) 185-3-2	90	120	1154	800	1954	512	480	853
XR(L) 185-3	110	150	1184	950	2134	550	505	1120
XR(L) 185-4-4	110	150	1312	950	2262	550	505	1138
XR(L) 185-4-2	132	175	1312	950	2262	550	505	1208
XR(L) 185-4-1	132	175	1312	950	2262	550	505	1208
XR(L) 185-4	132	175	1312	950	2262	550	505	1208

XQ-XR(L)

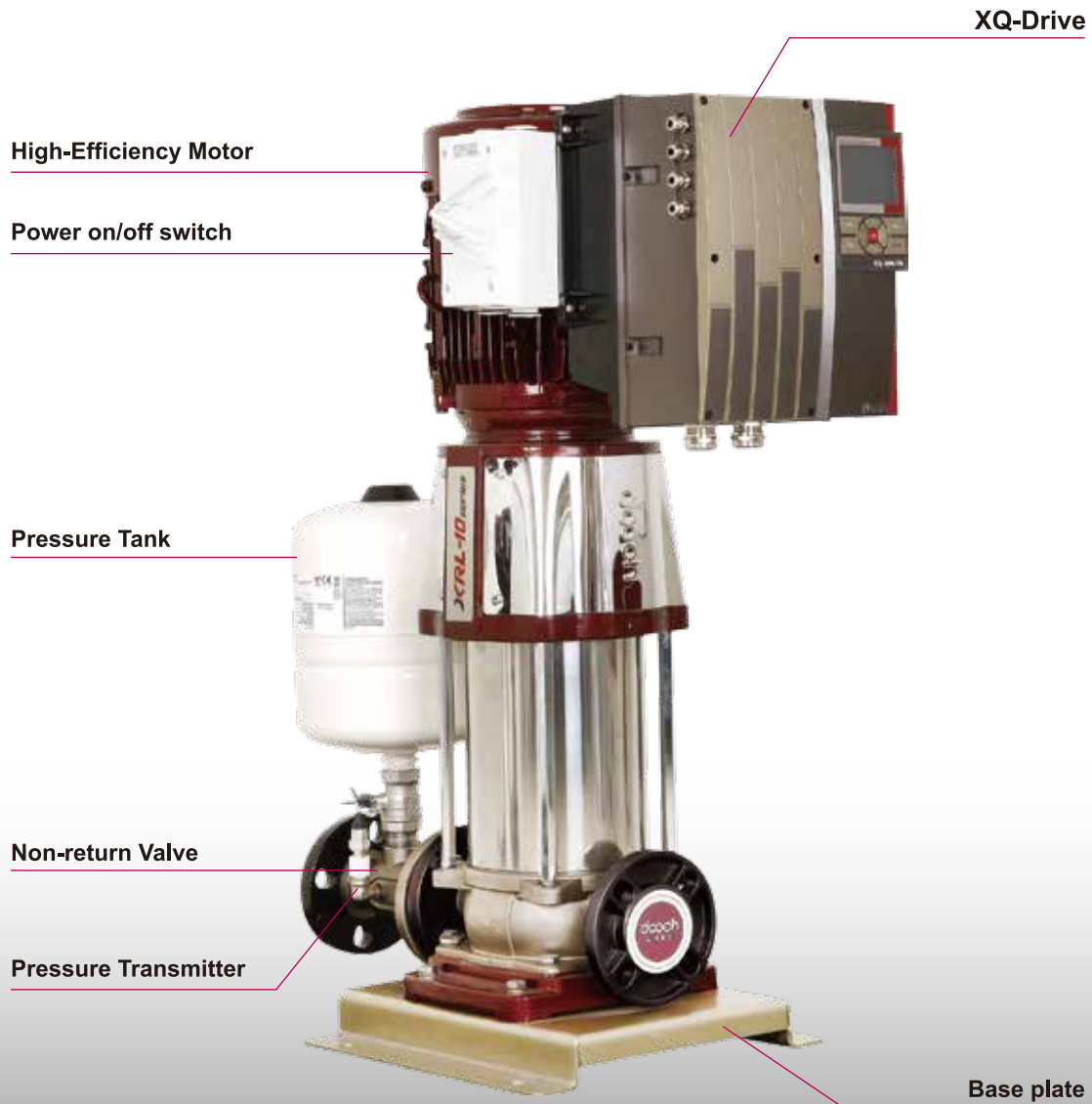

XQ-XR(L)

XQ-XR(L) pumps are built on the basis of XR(L) pumps. Enhanced with the XQ-Drive, the XR(L) pump together with the appropriate sensor is turned into an intelligent, variable speed pumping system. The XQ-Drives are frequency converter integrated into the pump which adjusts the motor speed to provide constant pressure or differential pressure to the flow rate.

Specification

- Max. Flow : 240m³/h
- Max. Head: 249m
- Motor Power : 0.75~22kW (1~30HP)
- Power specification : 3Φ×380~440V / 60Hz

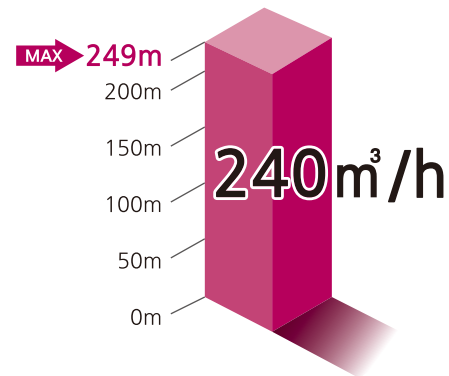

Functions

- Pressure settings
- Alternative operation
- Pump Freeze Protection
- Automatic detection of low flow on discharge
- Automatic recovery after power outage
- XQ drive will protect the pump
- Operation display and storage
- Equipped with a RS485

Features

- 3.5" color display
- Built-in EMC filter/DC reactor
- Reduce noise and harmonic distortion
- Energy Saving (Up to 50%)
- Maintains constant pressure
- Simplicity (Eliminates separate control panels)
- Soft start functionality to minimize mechanical stress on the pumping system

Main Components



**High Efficiency Pump
XR(L) Series**



**V.F.D.
XQ-Drive**



Pressure Tank



Non-return Valve

NSQ-XR(L)



NSQ-XR(L) Series

BUILT-IN VFD VERTICAL MULTI-STAGE CENTRIFUGAL PUMP

NSQ-XR(L)

NSQ-XR(L) pumps are built on the basis of XR(L) pumps. Enhanced with the NSQ-Drive, the XR(L) pump together with the appropriate sensor is turned into an intelligent, variable speed pumping system. The NSQ-Drives are frequency converter integrated into the pump which adjusts the motor speed to provide constant pressure or differential pressure to the flow rate.

Specification

- Max. Flow : 240m³/h
- Max. Head: 249m
- Motor Power : 0.75~22kW (1~30HP)
- Power specification : 3Φ×380~440V / 60Hz

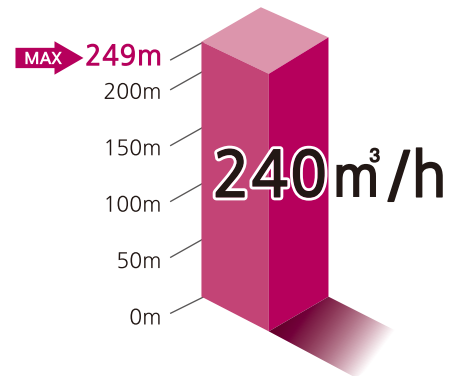

Functions

- Pressure settings
- Alternative operation
- Pump Freeze Protection
- Automatic detection of low flow on discharge
- Automatic recovery after power outage
- NSQ drive will protect the pump
- Operation display and storage
- Equipped with a RS485

Features

- Energy Saving (Up to 50%)
- Maintains constant pressure
- Simplicity (Eliminates separate control panels)
- Soft start functionality to minimize mechanical stress on the pumping system

Main Components



High Efficiency Pump
XR(L) Series



V.F.D.
NSQ-Drive



Pressure Tank



Non-return Valve