

User's Manual For Booster Pump N747D Controller

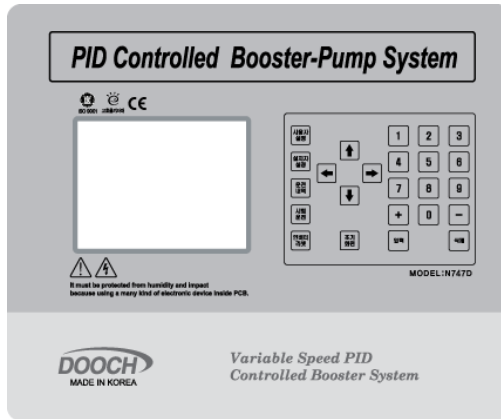

DOOCH CO., LTD

Contents

Chapter #1 The composition and features of controller

- 1. Features of controller 5
- 2. Major Functions of controller 6
- 3. Composition of controller 7

Chapter #2 Key operation of user

- 1. Key operation of user setting 10
- 2. Display of user setting 10
- 3. Change of user setting(1) 11
- 4. Change of user setting(2) 15
- 5. Change of user setting(3) 19

Chapter #3 Key operation of installer

- 1. Key operation of installer setting 26
- 2. Display of user setting 26
- 3. Change of installer setting(1) 27
- 4. Change of installer setting(2) 32
- 5. Change of installer setting(3) 36

Chapter #4 Key Operation of pump operation history

- 1. Confirmation of pump operation history 42
- 2. Confirmation of alarm history 43

Chapter #5 Key operation of test operation

- 1. Test operation key 46

Chapter #6 Other Keys

- 1. Inverter reset Key 49
- 2. Key of Initial display 49
- 3. Alarm display and Reaction..... 49

Chapter #7 Appendix

- 1. Control Board Arrangement and Description.... 52
- 2. Check items 55
- 3. Pump Test operation 57
- 4. Emergency Operation..... 58
- 5. RS-485 Communication 60

Chapter #1

The composition and features of controller

1. Features of controller
2. Functions of controller
3. Composition of controller

1. Features of controller



This advanced computer control device has been achieved its controlling of pump's RPM by inverter through the newest electronic technology, and equipped with presumptive terminal pressure control technology and various intelligent functions which can determine and control the pressure of water supply according to the amount of supplied water and usage.

Up to 6 pumps can be controlled with functions generally such as; stopping low flow using pressure tank, control, scheduled operation, warning abnormal state, full automated sequential operation, interval shift operation, skipping failed pump automatically, displaying operation data and data storing

Remote controlling and monitoring functions by remote modem communication, and easy operating for anyone by displaying of all screen view in Korean./ English / Chinese.

2. Major functions of controller

Major function	Description
Inverter-fix type	Select inverter-fix type from menu.
LCD Monitor	Displaying variety information through large LCD screen.
LCD Display in Korean	Easy operation and control for anyone by Korean menu.
Select display language	Select Korean(default) / English/ Chinese/ Spanish from menu.
Control latest PID	Latest PID Control by micro processor.
sequential operation	Operating and stopping motor sequentially.
Preventing idling	In case of no water in suction piping, operating stop and alarming
Skipping failed pump	If any pump is failed, the next pump is operated skipping the failed one.
Preventing excessive current to motor	Automatic-trip in case operating current of motor is abnormal.
Prevention of abnormal high voltage	Preventing abnormal high voltage by pressure switch against to any problems in pressure sensor.
Scheduled operation.	Available to vary operating conditions by time/day/month.
Self-access operation	Optimized operation through self-assessment
Alarming high pressure	When specified pressure/time is exceeded, pump stops and alarm is given.
Alarming low pressure	When every pumps are operated under specified pressure even during the continuous operating, then alarm is given (preventing low pressure).
Correction of sensor value	Correcting when sensor value does not match with analog gauge.
Record operation data and save	Record various operation data and save.
Display alarmed description and save	Displays various alarmed descriptions and save.
Emergent operation	Emergent operation by pressure switch in case controller and pressure transmitter are in failure.
Shift operation	After certain period of operation, main pump function is shifted so that pumps can be operated equally.
Spare sensor	Spare pressure sensor is connected, so that when one pressure sensor is failed, other sensor is employed automatically to replace the function.
Contact terminals by pump	Outputs operation and error by pump to external contact terminal.
Input external analog data	Input of multi-functional external analog data
CAN communication	Supporting CAN and RS485 communication
485 communication	
Inverter options	Operating with two inverters simultaneously

3. Composition of controller

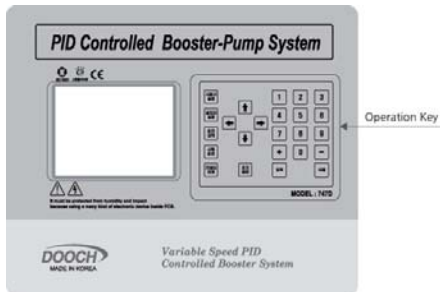

< Controller External >

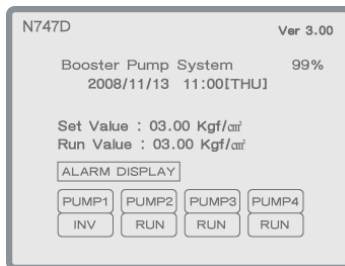

■ Controller is consisted of LCD play and operation Keys.

- LCD Display : It displays system information.







- Operation Key : It is for data setting and checkup data.

- USER SET** : It is for booster system user.
- ENC SET** : It is for booster system installer.
- OPER DATA** : It is for checking operation data.
- TEST RUN** : It is for checking motor rotation direction.
- USER SET** : In case of inverter fault, it is for reset inverter.
- MAIN DISP** : It is for recovery to the main display.
- 0 ~ 9** : Setting value.

 ,  : + , - Setting value.

 : It is for saving setting value and checking operation history/
alarm history

 : It is for deleting operation history/alarm history

 ,  ,  ,  : It is for moving cursor to the menu.

Chapter #2

Key operation of user

1. Key operation of user setting
2. Display of user setting
3. Change of user setting(1)
4. Change of user setting(2)
5. Change of user setting(3)

1. Key operation of user setting

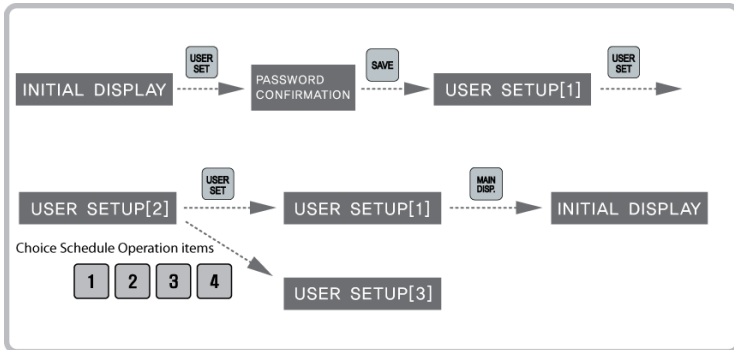

2. Display of user setting

■ User setup display [1]



■ User setup display [2]



User setup display [3]

■ The display of User setup [3] is related with User setup [2]

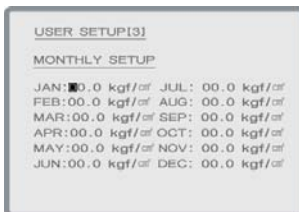

< Display of Monthly operation >

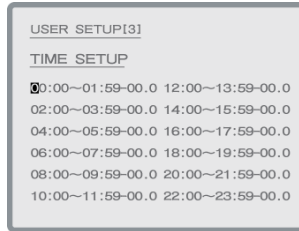
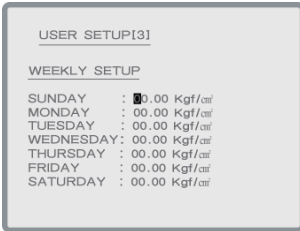

< Display of weekly operation >

< Display of timely operation >

3. The change of user setup[1]

1. Press installer setup on main display

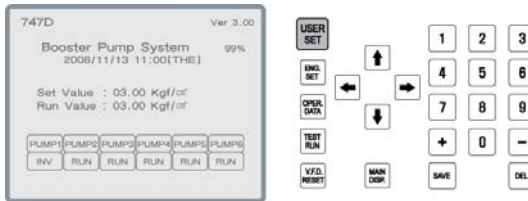

2. Input password and save (initial password is "0000")

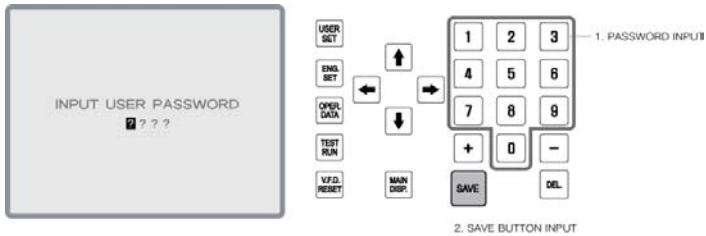

3. In user setup [1], move to desire display with cursor.

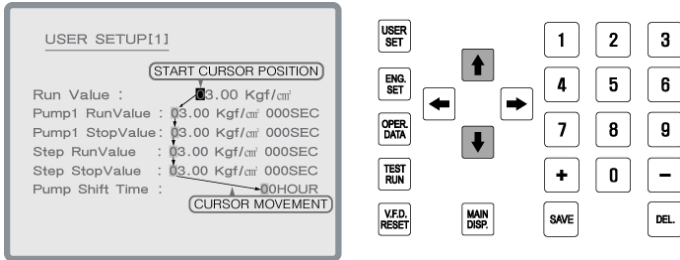

4. Move to desire display with cursor

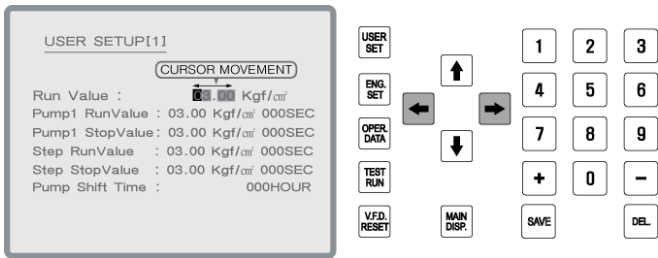

※ Cursor can be moved to left / right.

5. Setting value can be changed by figure Keys.

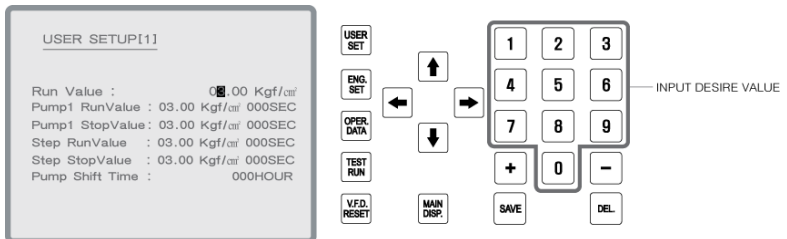

6. After setting, press "save" .

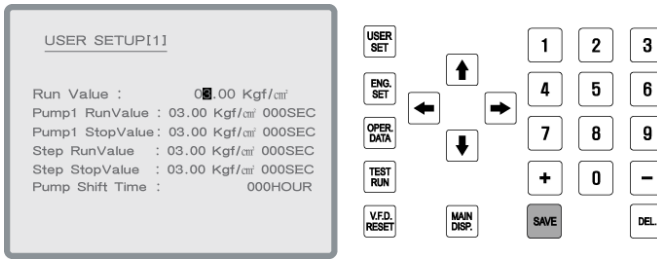

► **The adjustable items in the user setting [1] are as below.**

- **Setting pressure: Target water pressure to operate.**

Change of predetermined pressure.

(Example: In case current set value is 03.00 kgf/cm²)

1. Using , Key, select .
2. Initially the first '0' of the '03.00' blinks.
3. Using , Key, select position to be changed in '03.00 kgf/cm² ' .
4. After change using ~ Key, make sure to press Key.

※ Set value is not changed until input key is pressed.

※ When predetermined pressure is changed, the high pressure value becomes setting pressure +2kgf/cm² automatically.

-The change of **auxiliary stop pressure**

(Example: In case current set value is 00.2 kgf/cm²)

1. Using , Key, select .
2. Initially the first '0' of the '00.20' blinks.
3. Using , Key, select position to be changed in '00.20 kgf/cm² ' .
4. After change using ~ Key, make sure to press Key

- **Auxiliary stop pressure** : it means the pressure to stop the auxiliary pump.

When current pressure decreases higher than "setting pressure + auxiliary operation pressure", then auxiliary pump will stop. If setting pressure is 03.00 kgf/cm² and auxiliary pressure is 00.50kgf/cm², 005 second, and current pressure is higher than 3.5kgf/cm², then auxiliary pump will stop after 5 seconds.

Change of auxiliary stop pressure.

(Example: In case current set value is 00.30 kgf/cm²)







1. Using , Key select .
2. Initially the first '0' of the '03.00' blinks.
3. Using , Key, select the position to be changed in '00.30 kgf/cm² ' .
4. Using ~ Key, change to required value, then make sure to press Key.

※ Set value is not changed until input key is pressed.

- Step operational pressure(Emergent operational pressure) :

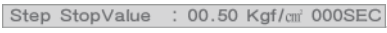
When "step operation 1" has been set by user or inverter error occurs, pump runs if "setting pressure-current pressure" is lower than specified emergent operating pressure. Change of step operational pressure.

(Example: In case current set value is 00.50 kgf/cm²)









1. Using  ,  Key, select  
 2. Initially the first '0' of the '00.50' blinks.
 3. Using  ,  Key, select the position to be changed in '00.50 kgf/cm²'.
 4. Using  ~  Key, change to required value, then make sure to press Key.
- ※ Setting value will not be changed until input key is not pressed.

step stop pressure (emergent stop pressure) :

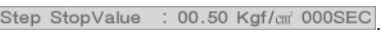
When "step operation 1" has been set by user or inverter error occurs, pump runs if "setting pressure-current pressure" is lower than specified emergent operating pressure.

Change of step stop pressure.

(Example: In case current set value is 00.50 kgf/cm²)









1. Using  ,  Key, select  
 2. Initially the first '0' of the '00.50' blinks.
 3. Using  ,  Key, select the position to be changed in '00.50 kgf/cm²'.
 4. Using  ~  Key, change to required value, then make sure to press  Key.
- ※ Set value is not changed until input key is pressed.

- Shift time of main pump :

When the specified time as the shift time of main pump is over, the main pump is changed. However, while the pump is in operating, its operating mode is maintained until 2:00am then shifted forcibly. Setting is available up to '99', and when setting is in '00', the main pump is shifted whenever inverter stops.

Change of main pump shift time

(Example: In case current set value is 24 hours.)

1. Using  ,  Key, select  
 2. Initially the first '2' of the '24' blinks.
 3. Using  ,  Key, select the position to be changed in '24'.
 4. Using  ~  Key, change to required value, then make sure to press  Key.
- ※ Set value is not changed until input key is pressed.
 ※ In case of forced shift, all pump stops for a while.

4. The change of user setup[2]

1. Press user setup on main display.

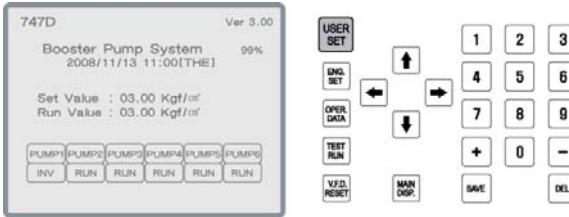

2. Input password and save (initial password is "0000")

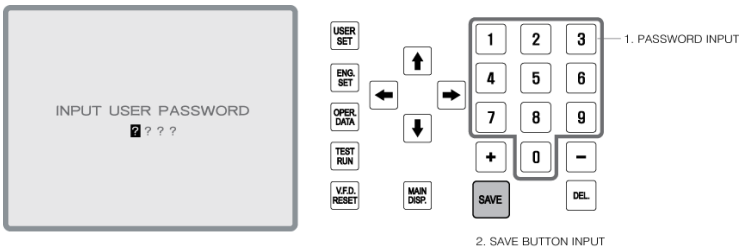

3. Press user setup key on user setting [1].

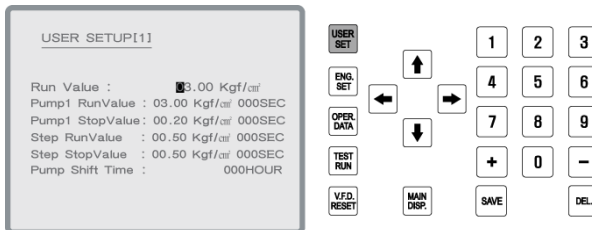

4. In user setup [2], move to desire display with cursor.

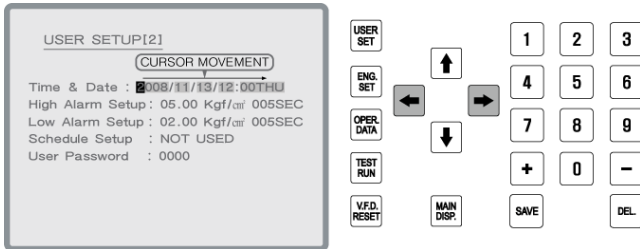
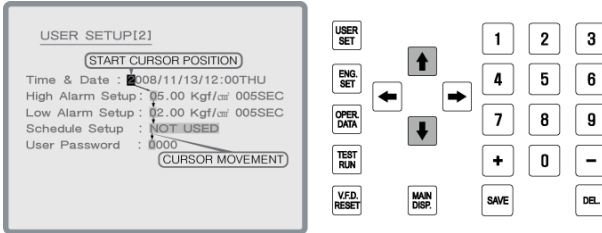

5. Setting value can be changed by figure Keys.

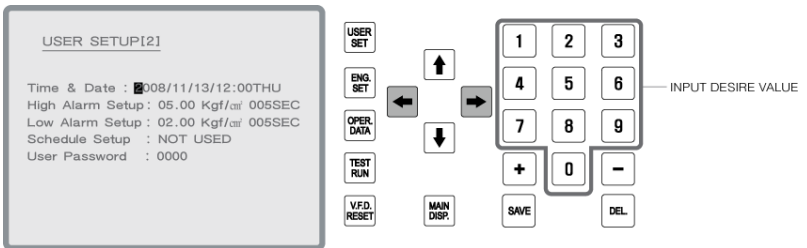

6. After setting, press "save".

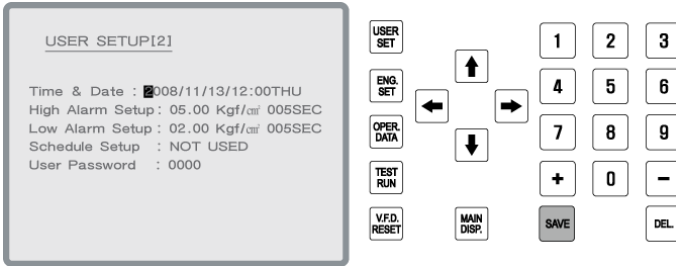

► **Changeable items in user setting [2] are as below.**

- **Time setting** : 2008/11/13 12:20 Thursday

It displays in the order of year/month/day time :minute days, and if it does not matched with present time then adjust it.

Adjust of time settings

(Example: In case of change "2008/11/13 12:00 Thursday" to "2008/11/13 24:00 Thursday")

1. Using , Key, select **Time & Date : 2008/11/13/12:00THU**.

2. The first '2' of the '2008/11/13 12:00 Thursday' blinks.

3. Using ~ Key, enter in the order of 2,0,0,8,1,1,1,3,1,2,0 and 0 (Thurs).

When no change is required or in case of wrong input, it's available to move to required position using , Key.

The last number means day of the week as below;

1 : Mon 2 : Tue 3 : Wed 4 : Thurs 5 : Fri 6 : Sat 7 : Sun

4. After changing to required value, make sure to press Key.

※ Set value is not changed until input key is pressed.

- **Setting high pressure alarm** : 00.00kg/cm² 000second

When water pressure sustains at above than specified pressure (00.00) for more than 000 seconds, alarm is to be given.

Change settings of high pressure alarm

(Example: in case of to change 05.00 kg/cm² 005 seconds to 04.00 kg/cm² 003seconds)

1. Using , Key, select **High Alarm Setup : 05.00 Kg/cm² 005SEC**.

2. Initially the first '0' of the '05.00 kg/cm² 005 second' blinks.

3. Using ~ Key, enter in the order of 0, 4, 0, 0, 0 and 3.

In case no change is required or wrong input, moving to desired position is available by using , Key.

4. After changing to required value, make sure to press Key.

※ Set value is not changed until input key is pressed.

※ When setting pressure of user setting [1] is changed, setting pressure of the high pressure alarm settings is automatically set as +2kgf/cm².

- Setting of low pressure alarm : 00.00kgf/cm² 000seconds .

When water pressure sustains at lower than specified pressure (00.00) for more than 000 seconds, alarm is to be given.

Change of lower pressure alarm setting

(Example: in case of to change 00.00 kgf/cm² 005seconds to 00.20 kgf/cm² 005seconds)

- Using , Key, select .
- Initially the first '0' of the '00.00 kgf/cm² 005 seconds' blinks.
- Using ~ Key, enter in the order of 0, 0, 2, 0, 0, 0 and 5 .
In case no change is required or wrong input, moving to desired position is available by using , Key.
- After changing to required value, make sure to press Key.
※ Set value is not changed until input key is pressed.

- **Setting of scheduled operation** : Available to select among No use / Monthly operation / Weekly operation / Operation by time frame. Initial setting is 'No use', and operation method can be selected with 0~3 number keys. Each number stands for; 0 : No use 1 : Monthly operation 2 : Weekly operation 3: operation by time frame
Change setting of scheduled operation.
(Example: To change "scheduled operation : no use" to " scheduled operation : operation by time frame")

- Using , Key, select .
- "No use" blinks.
- Enter "3" among ~ Keys.
(0 : No use 1 : Monthly operation 2 : Weekly operation 3: operation by time frame)
- After changing to required value, make sure to press Key.
※ Set value is not changed until input key is pressed.
- To use scheduled operation, the settings shall be changed in " user operation [3].
Refer to the changes in "user operation [3]" for detail information.

- **Change of user password** : N747D is designed to set password in order to prevent others from tampering settings without authorization. Initial password is set as 0000.
Change of user password

(Example: To change "use password : 0000" to " ser password : 1234")

- Using , Key, select .
- User password : Initially the first '0' of the '0000' blinks.
- Using , Key, enter 1, 2, 3, 4.
- After changing to required value, make sure to press Key.
※ Set value is not changed until input key is pressed.

5. The change of user setup[3]

1. Press user setup on main display.

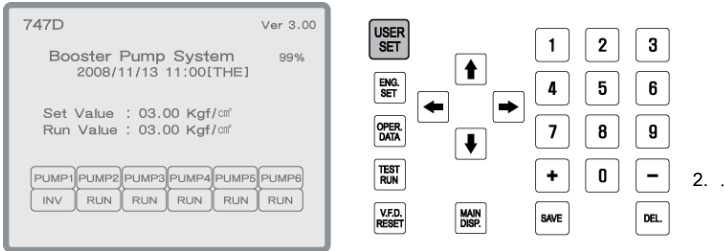

Input password and save (initial password is "0000")

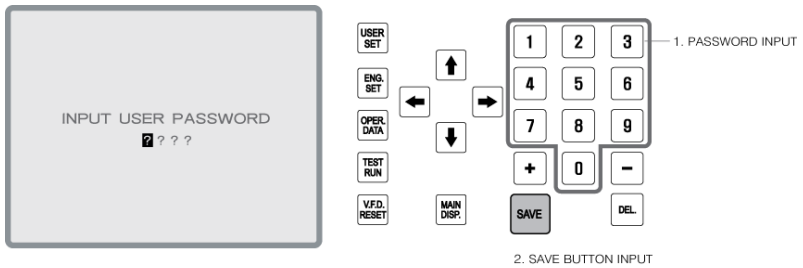

3. Press user setup key on user setting [1].

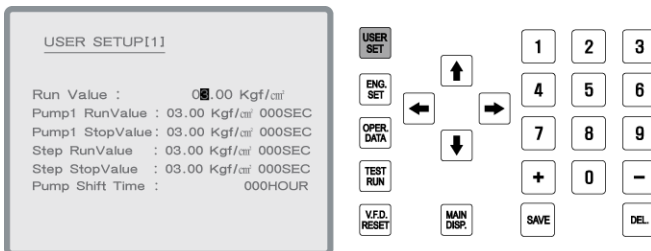

4. In user setup [2], move to schedule setup with cursor.

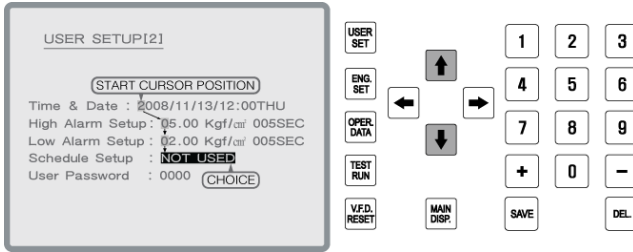

5. Choose desire figure from "0" to "3".

0 : Not used 1 : Monthly operation 2 : Weekly operation 3 : Timely operation

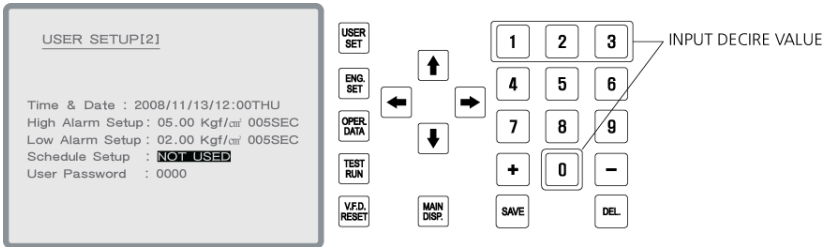

6. After changing to operation setup, make sure to press **SAVE** Key.

Set value is not changed until **SAVE** input key is pressed.

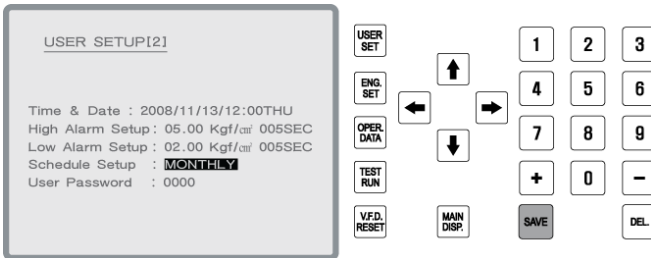

7. After pressing  Key, press user setup to move user setup [3].

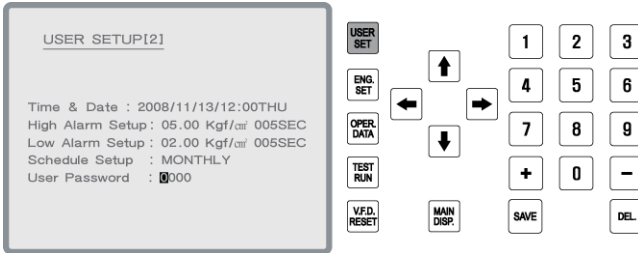

8. In user setup[3], choose desire menu with cursor.

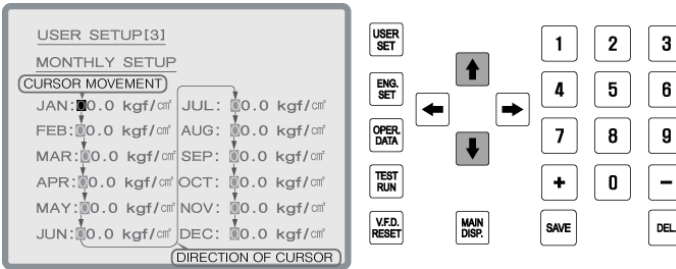

9.

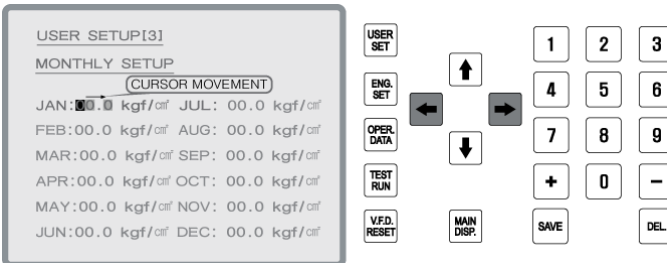

10. Change the desire value with figure Keys.

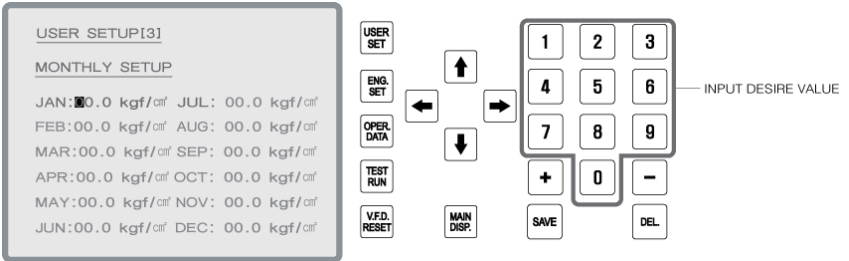

11. After changing to operation setup, make sure to press **SAVE** Key.

Set value is not changed until **SAVE** input key is pressed.

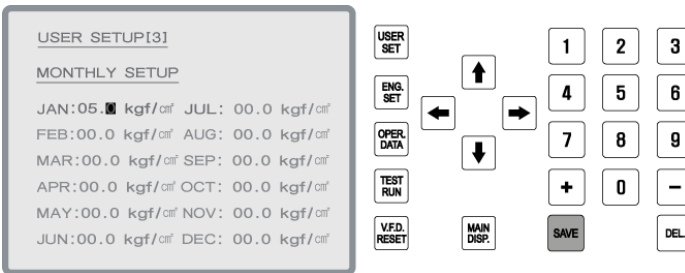

► **Changeable items in user settings [3] as below.**

- **Monthly scheduled operation.** : Any operation by monthly can be scheduled and executed.

To change settings, select monthly operation from the scheduled operation in “user setting [2] using **1** Key, then press ‘user setting button’ to move to “user setting [3] and change it.

Monthly scheduled operation.

1. Using **↑** , **↓** Key, select item to be set.
2. Select required position in the items using **←** , **→** Key.
3. Using **0** ~ **9** Key, change to required value, then make sure to press **SAVE** Key.
 ※ Set value is not changed until input key is pressed.

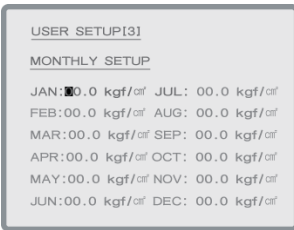

<Screen configuration of monthly operation>

- **Weekly scheduled operation.** : Any operation by weekly can be scheduled and executed.

To change settings, select weekly operation from the scheduled operation in “user setting [2] using **2** Key, then press ‘user setting button’ to move to “user setting [3] and change it.

Weekly scheduled operation.

1. Using **↑** , **↓** Key, select item to be set.
2. Select required position in the items using **←** , **→** Key.
3. Using **0** ~ **9** Key, change to required value, then make sure to press **SAVE** Key.
 ※ Set value is not changed until input key is pressed.

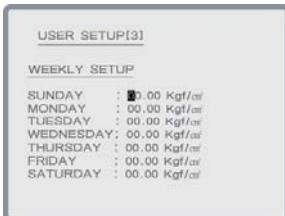







< Screen configuration by day operation >

Scheduled operation by time frame. : Any operation by time frame can be scheduled and executed.

To change settings, select by-time frame operation from the scheduled operation in

“user setting [2] using  Key, then press ‘user setting button’ to move to “user setting [3] and change it.

Scheduled operation by time frame.

1. Using  ,  Key, select item to be set.
2. Select required position in the items using  ,  Key.
3. Using  ~  Key, change to required value, then make sure to press  Key.
 ※ Set value is not changed until input key is pressed.

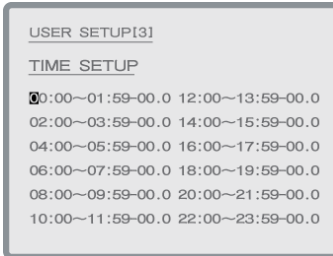

< Screen configuration by time frame operation >

Chapter #3

Key operation of installer

1. Key operation of installer setting
2. Display of user setting
3. Change of installer setting(1)
4. Change of installer setting(2)
5. Change of installer setting(3)

1. Installer Setup Key

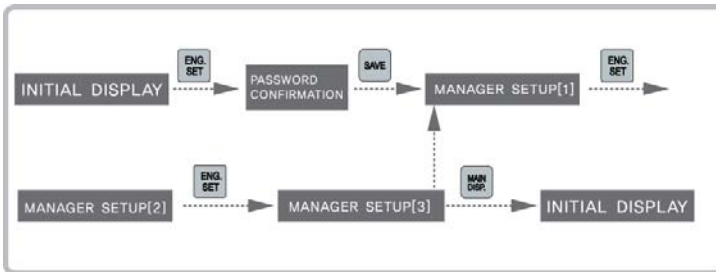

2. Display of Installer setup

■ Display of installer setup[1]

MANAGER SETUP[1]	
Min Out Rate	: 100%
P Value	: 080
I Value	: 030
D Value	: 010
Bad Zone	: 00.3 Kg _f /cm ²
SENSOR Value	: 16.0 Kg _f /cm ²
SENSOR Adjust	: 100.3 Kg _f /cm ²
Run Type	: FIX MAIN PUMP

■ Display of installer setup[2]

MANAGER SETUP[2]	
Max Pressure	: 10.0Kg _f /cm ²
Winter	: NOT USED
Password	: 0000
Initialize	: NO

■ Display of installer setup[3]

MANAGER SETUP[3]	
RS-485	: NOT USED
SLAUE ID	: 085
BAUD RATE	: 9600 bps
DELAY TIME	: 0000 ms
DRIVE MODE	: RS-485
<hr/>	
CAN	: NOT USED
BAUD RATE	: 40 kbps

3. The change of installer setup[1]

1. Press ENG SET key on main display.

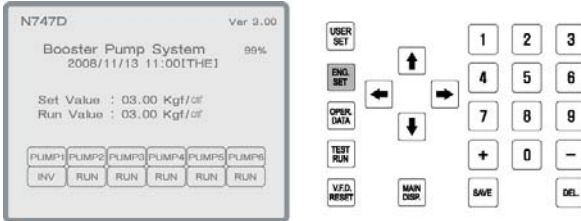

2. Input password and save (initial password is "0000")

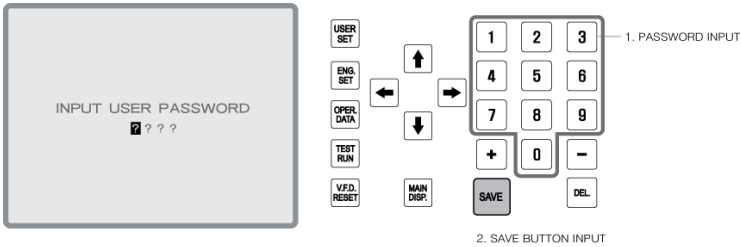

3. In installer setup [2], move to desire item with cursor.

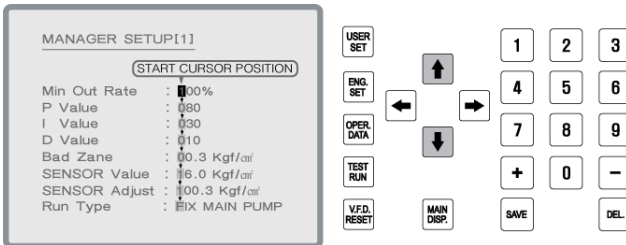

4.

USER SETUP[11]

CURSOR MOVEMENT

Run Value : 00.00 Kgf/cm²

Pump1 RunValue : 03.00 Kgf/cm² 000SEC

Pump1 StopValue : 03.00 Kgf/cm² 000SEC

Step RunValue : 03.00 Kgf/cm² 000SEC

Step StopValue : 03.00 Kgf/cm² 000SEC

Pump Shift Time : 000HOUR

Keypad: USER SET, ENG. SET, OPER. DATA, TEST RUN, V.F.D. RESET, MAIN DISP., SAVE, DEL, 1-9, 0, +, -, ↑, ↓, ←, →

5. Setting value can be changed by figure Keys.

MANAGER SETUP[11]

Min Out Rate : 00%

P Value : 080

I Value : 030

D Value : 010

Bad Zane : 00.3 Kgf/cm²

SENSOR Value : 16.0 Kgf/cm²

SENSOR Adjust : 100.3 Kgf/cm²

Run Type : FIX MAIN PUMP

Keypad: USER SET, ENG. SET, OPER. DATA, TEST RUN, V.F.D. RESET, MAIN DISP., SAVE, DEL, 1-9, 0, +, -, ↑, ↓, ←, →

INPUT DESIRE VALUE

6. After changing to operation setup, make sure to press **SAVE** Key.

Set value is not changed until **SAVE** input key is pressed.

MANAGER SETUP[11]

Min Out Rate : 00%

P Value : 080

I Value : 030

D Value : 010

Bad Zane : 00.3 Kgf/cm²

SENSOR Value : 16.0 Kgf/cm²

SENSOR Adjust : 100.3 Kgf/cm²

Run Type : FIX MAIN PUMP

Keypad: USER SET, ENG. SET, OPER. DATA, TEST RUN, V.F.D. RESET, MAIN DISP., SAVE, DEL, 1-9, 0, +, -, ↑, ↓, ←, →







► **Changeable items in user settings [1] as below.**

- The minimum operation rate of inverter

Set the minimum inverter output in %. When inverter operates, set 60Hz at 100%, or set value is 50% then operate from 30Hz.

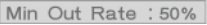
Change of the minimum operation rate if inverter.

(Example: To change 50% to 60%)

1. Using  ,  Key, select → .
2. Initially the first '0' of the '050' blinks.
3. Enter in order of 0, 6 and 0 using  ~  Key.
4. After changing to required value, make sure to press  Key.







※ Set value is not changed until input key is pressed.

- Proportional factor (P) : It is a proportional factor in PID control variables.

Range : 1 ~ 100

Change of proportional factor (P) settings.

(Example: In case of to change 80 to 90)

1. Using  ,  Key, select → .
2. Initially the first '0' of the '080' blinks.
3. Enter in order of 0, 9 and 0 using  ~  Key.
4. After changing to required value, make sure to press  Key.







※ Set value is not changed until input key is pressed.

- Constant of integration (I) : It is a constant of integration in PID control variables.

Range : 1 ~ 100

Change of constant of integration (I) settings.

(Example: In case of to change 30 to 40)







1. Using  ,  Key, select → .
2. Initially the first '0' of the '030' blinks.
3. Enter in order of 0, 4 and 0 using  ~  Key.
4. After changing to required value, make sure to press  Key.

※ Set value is not changed until input key is pressed.

- **Constant of differential (D)** : It is a constant of differential in PID control variables.

Range : 1 ~ 100

Change of constant of differential (I) settings. (Example: In case of to change 10 to 20)

1. Using  ,  Key, select → 
2. Initially the first '0' of the '010' blinks.
3. Enter in order of 0, 2 and 0 using  ~  Key.
4. After changing to required value, make sure to press  Key.

※ Set value is not changed until input key is pressed.







- **Dead zone** : It's the detection range of non-flow. It works when only one inverter operates.

I.e., if only one pump operates and current state of that current pressure > (setting pressure – Dead zone) is sustained for more than 20 seconds, inverter decelerates in order to inspect the state of non-flow. Even if it decelerates, when current pressure > (settings pressure – Dead zone), it stops.

Range : 0.0 ~ 2.0

Change of dead zone settings

(Example: In case of to change 0.3kgf/cm² to 0.4kgf/cm²)

1. Using  ,  Key, select → 
2. Initially the first '0' of the '003' blinks.
3. Enter in order of 0, 0 and 4 using  ~  Key.
4. After changing to required value, make sure to press  Key.



※ Set value is not changed until input key is pressed.



- **Maximum sensor value** : Enter the maximum value as far as pressure sensor measures.

Range : 1.0 ~ 25.0

Change of maximum sensor value.

(Example: in case of to change 16.0kgf/cm² to 20.0kgf/cm²)

1. Using  ,  Key, select → 
2. Initially the first '1' of the '16.0' blinks.

3. Enter in order of 2, 0 and 0 using  -  Key.
4. After changing to required value, make sure to press  Key.







※ Set value is not changed until input key is pressed.

- **Corrected value of sensor** : This function corrects the deviation between the analog or digital pressure gauge in the piping and current pressure indicated in panel LCD

Range : 1.0 ~ -1.0

Change of sensor maximum value settings.

(Example: in case of to change 16.0kgf/cm² to 20.0kgf/cm²)

1. Using ,  Key, select  .
2. Initially the first '0' of the '00.3' blinks.
3. Enter in order of 0, 0 and 4 using  -  Key.
4. After changing to required value, make sure to press  Key.

※ Set value is not changed until input key is pressed.

- **Operating method** : To set operation method of pump.

1 : Operating by fixed-inverter

Inverter is fixed for one pump operation, and when all pumps stop, move the inverter .

2 : sequential 1 operation







Sequential operation by pressure sensor without inverter(Automatically switched when inverter failure.)

3 : sequential 2 operation

Sequential operation by pressure switch without inverter or pressure sensor (manually switched).

Change of operation method settings.

(Operating method: Example – In case of change main pump fixed method to sequential 2 operation)

1. Using ,  Key, select  .
2. Enter 3 with using  -  Key .

(1: Operating by fixed-inverter 2: Sequential 1 operation 3: Sequential 2 operation)

3. After changing to required value, make sure to press  Key.

※ Set value is not changed until input key is pressed.

4. The change of installer setup[2]

1. Press ENG SET key on main display.

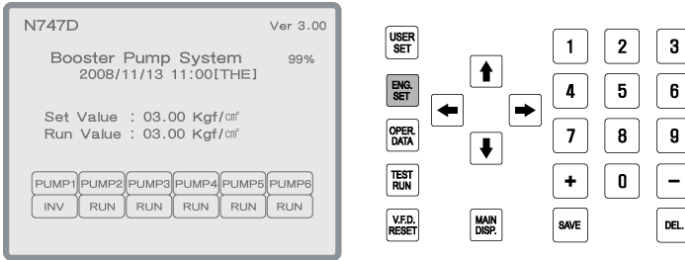

2. Input password and save (initial password is "0000")

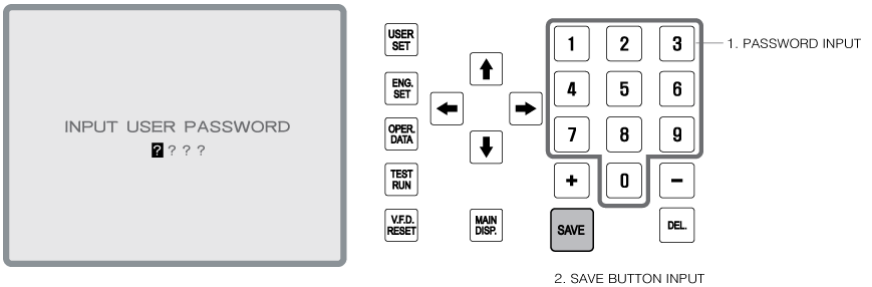

3. Press ENG SET on installer setup[1].

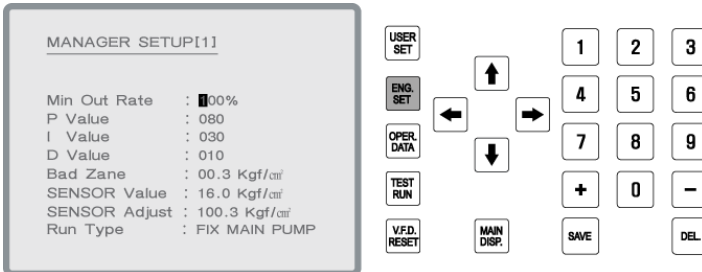

4. In installer setup [2], move to desire item with.

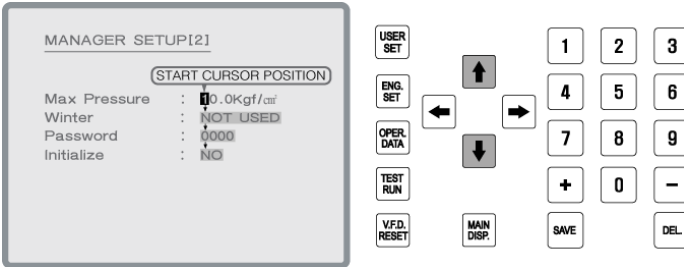

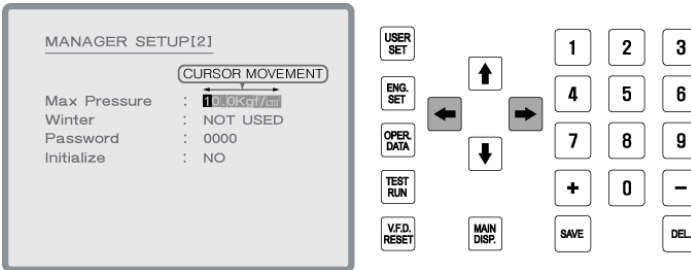

5.

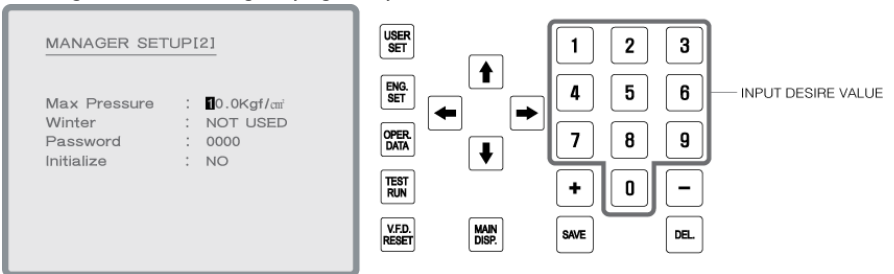

6. Setting value can be changed by figure Keys.



7. After changing to operation setup, make sure to press  Key.

Set value is not changed until  input key is pressed.

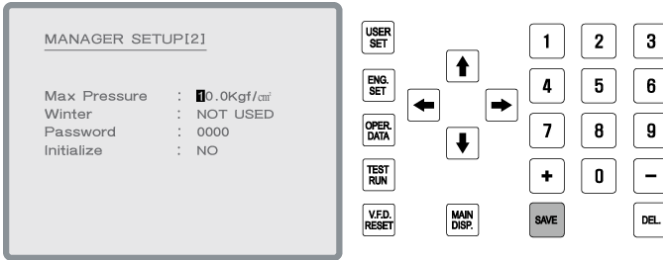







► **The changeable items in installer setting [2] are as below;**

- **Pump maximum pressure** : Entering the maximum pressure of pump.

Changing of pump maximum pressure settings.

(Example: In case of to change 10.0 to 20.0)









- Using  ,  Key, select → 
- Initially the first '1' of the '10.0' blinks.
- Enter in order of 2, 0 and 0 using  ~  Key.
- After changing to required value, make sure to press  Key.

※ Set value is not changed until input key is pressed.

- **Preventing frozen rupture** : In order to prevent frozen rupture in cold season, if all pumps does not operate for one minute at below -1°C, main pump operates in 15Hz for 15 seconds then stops. After stopping, the main pump is transferred to next pump and operates as same condition in turns.

Change prevention of frozen rupture setting.

(Example: In case of change "No use" to "Use".)







- Using  ,  Key, select → 
- Enter by using  ,  Key.
 : No use,  : Use
- After changing to required value, make sure to press  Key.

※ Set value is not changed until input key is pressed.

- **Setting of installer's password** : Changing installer's password.

Change of installer's password

(Example: To change "Installer's password : 0000" to "User's password:1234")









1. Using  ,  Key, select → .
2. User's password : Initially the first '0' of the '000' blinks.
3. Enter by using  ~  Key.
4. After changing to required value, make sure to press  Key.

※ Set value is not changed until input key is pressed.

- **System initializing** : Initialize setting values to ex-factory value.

Change setting of system initialization.

(Example: In case to change "No" to "Yes".)

1. Using  ,  Key, select → .
2. Enter by using  ,  Key.
 : No  : Yes
3. After changing to required value, make sure to press  Key.

※ Set value is not changed until input key is pressed.

5. The change of installer setup[3]

1. Press ENG SET key on main display .

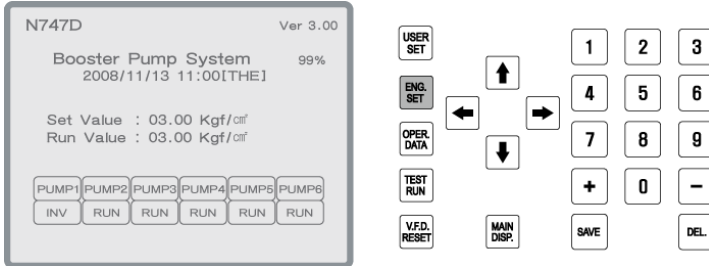

2. . Input password and save (initial password is "0000").

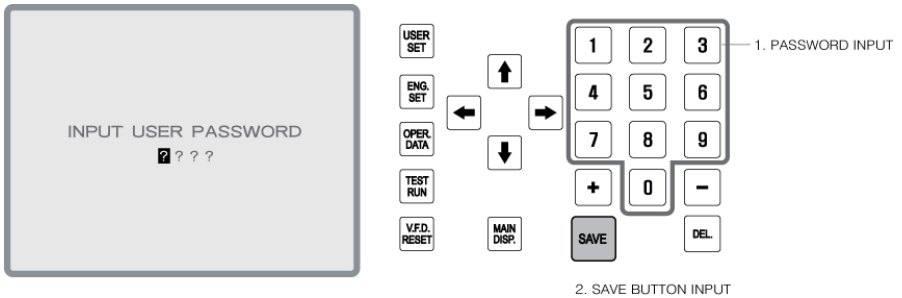

3. Press ENG SET on installer setup[1].

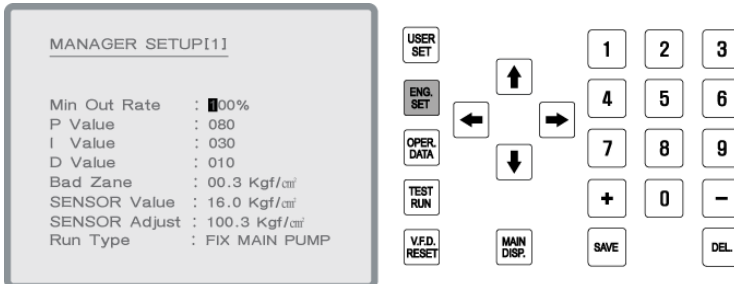

4. Press ENG SET on installer setup[2].

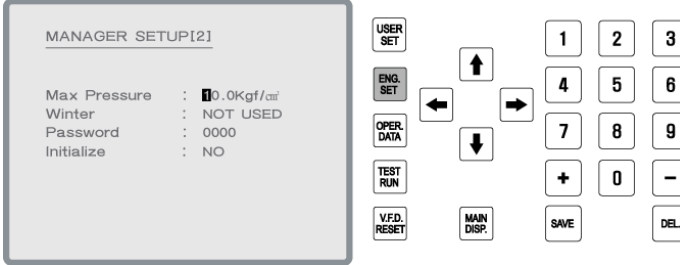

5. In installer setup [3], move to desire item with cursor..

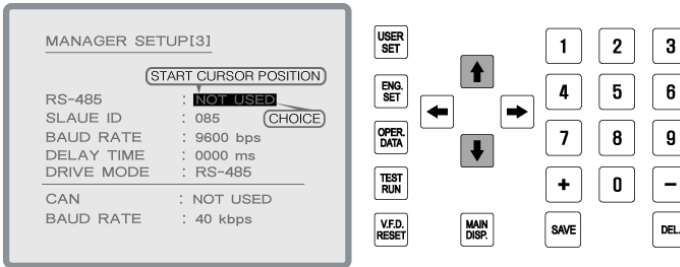

6. Setting value can be changed by figure Keys.

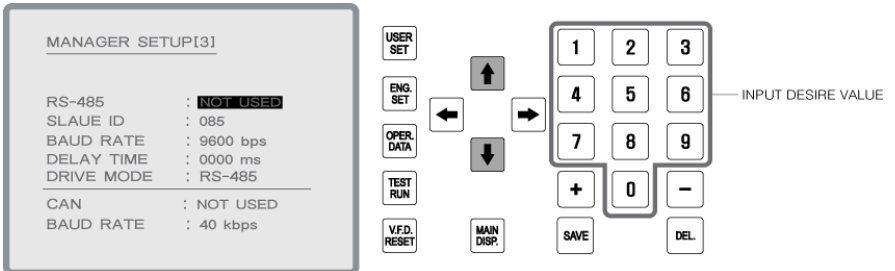

7. After changing to operation setup, make sure to press  Key.

Set value is not changed until  input key is pressed.

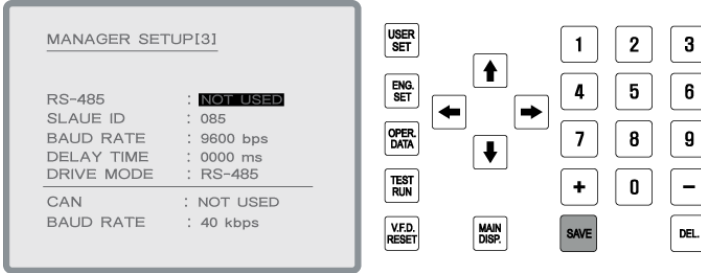









► **The changeable items in user setting [3] are as below;**

- **RS485** : Select whether to use RS485 communication or not.

Change of RS485 setting.

(Example: In case to change "No use" to "Use".)

- Using  ,  Key, select → .
- Enter by using  ,  Key.
-  : No use,  : Use
- After changing to required value, make sure to press  Key.







※ Set value is not changed until input key is pressed.

- **Slave ID** : Set Slave ID.

Range : 1 ~ 255

Change setting of Slave ID.

(Example: In case of to change 85 to 96)

- Using  ,  Key, select → .
- Initially the first '0' of the '085' blinks.
- Using  ~  Key, enter by the order of 0, 9 and 6.
- After changing to required value, make sure to press  Key.











※ Set value is not changed until input key is pressed.

- **BAUD RATE** : Select communication speed.

(0: 1200bps 1: 2400bps 2: 4800bps 3: 9600bps 4: 19200bps)

Change setting of BAUD RATE







(Example: In case of to change 9600bps to 1200bps)

1. Using  ,  Key, select → BAUD RATE : 9600bps.
2. Using  ~  Key, select communication speed to be changed.
 : 1200bps,  : 2400bps,  : 4800bps,  : 9600bps,  : 19200bps
3. After changing to required value, make sure to press  Key.
 ※ Set value is not changed until input key is pressed.

- **DELAY TIME** : Set delay time of communication responding.
 Range : 0 ~ 9999

Change DELAT TIME settings

(Example: In case of to change 0 to 20)







1. Using  ,  Key, select → DELAY TIME : 0000 ms.
2. Initially the first '0' of the '0000ms' blinks.
3. Using  ,  Key, select the position to be changed in '0000 ms'.
4. Using  ~  Key, enter by order of 0, 0 and 2.
5. After changing to required value, make sure to press  Key.
 ※ Set value is not changed until input key is pressed.

- **DRIVE MODE**: Setting for operation order .
 Controller : It is operated by Start/Stop switch on panel.
 RS-485 : It is operated by 485 communication

- ※ RS485 can be used by setting in DRIVE MODE.
- ※ In case of RS-485, It can't operated by Start/Stop switch on panel.

The change of DRIVE MODE setting







(Controller → RS-485)

1. Using  ,  Key, select → DRIVE MODE : Controller.
2. Input setting mode with  .  Key.
 : Controller,  : RS-485
5. After changing to required value, make sure to press  Key.
 ※ Set value is not changed until input key is pressed

- **CAN** : Select whether to use CAN communication or not.

Change CAN setting CAN .

(Example: To change "No use" to "Use")

1. Using  ,  Key, select. → CAN : NOT USED
2. Enter using  ,  Key.
 : No use,  : Use
3. After changing to required value, make sure to press  Key.













※ Set value is not changed until input key is pressed.

- **BAUD RATE** : Select communication speed.

(0 : 40kbps 1 : 50kbps 2 : 100kbps 3 : 200kbps 4 : 250kbps)

Change setting of BAUD RATE.

(Example: In case of to change 40kbps to 50kbps)

1. Using  ,  Key, select → .
2. Enter  among  ~  Keys.
 : 40kbps,  : 50kbps,  : 100kbps,  : 200kbps,  : 250kbps
3. After changing to required value, make sure to press  Key.

※ Set value is not changed until input key is pressed.

Chapter #4

Operation History Key

1. Confirmation of pump operation history
2. Confirmation of alarm history

1. Confirmation of pump operation history

1. Press operation Data key on main display.

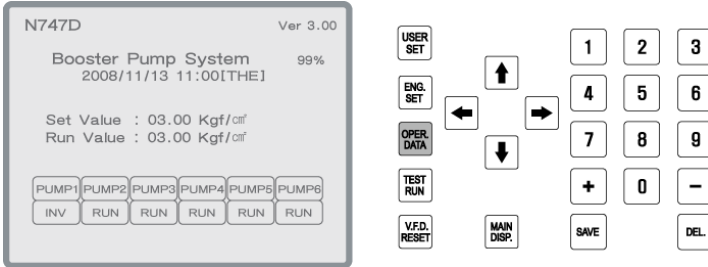

2. In operation data, move to desire menu with cursor.

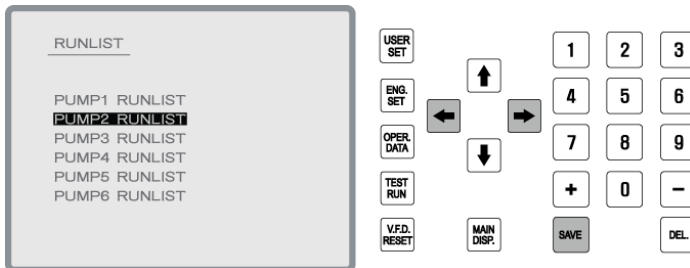
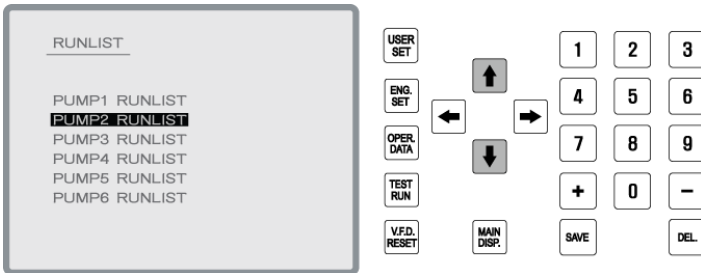

3. It shows pump operation history.

If you want to delete all pump operation history, press Del key.

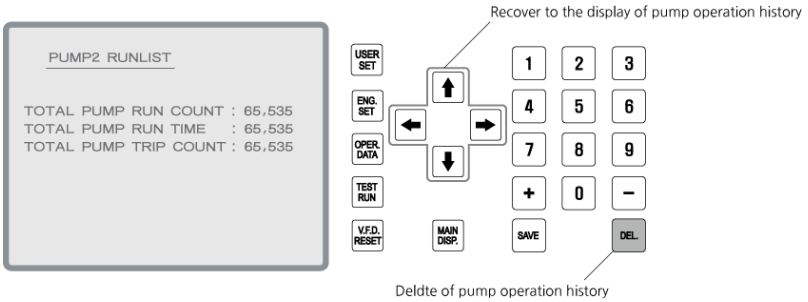

2. Confirmation of alarm history

1. Press operation Data key on main display

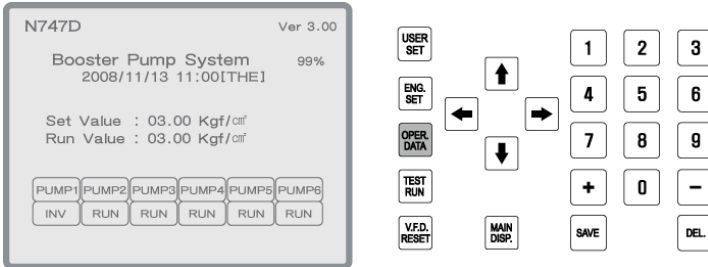

2. Press operation data key on operation data display.

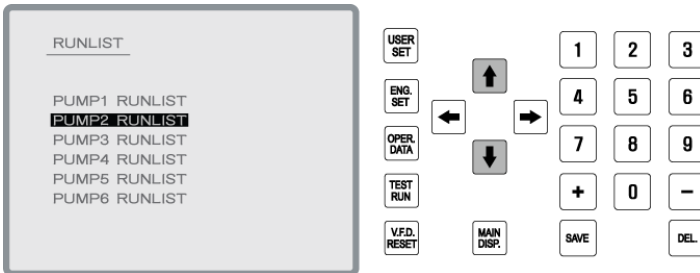

3. In alarm history display, move to desire menu with cursor

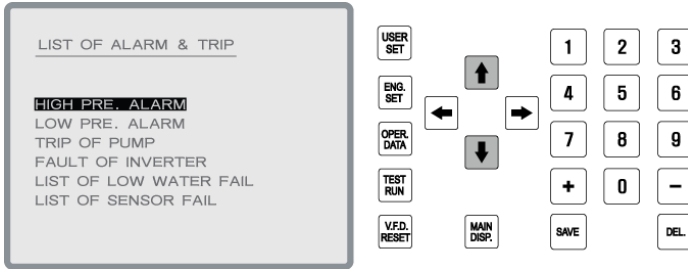

4.

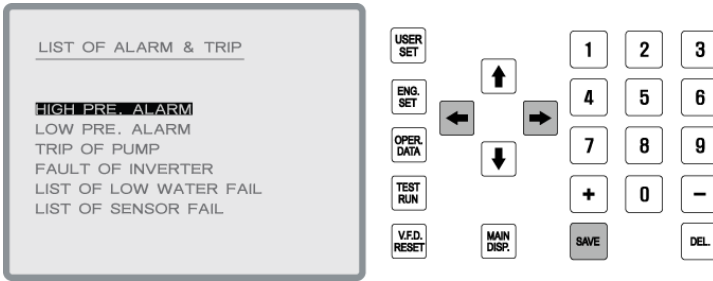

5. It display alarm history.

- It shows latest 10 alarm history..
- If you want to delete all alarm history, press DEL key.

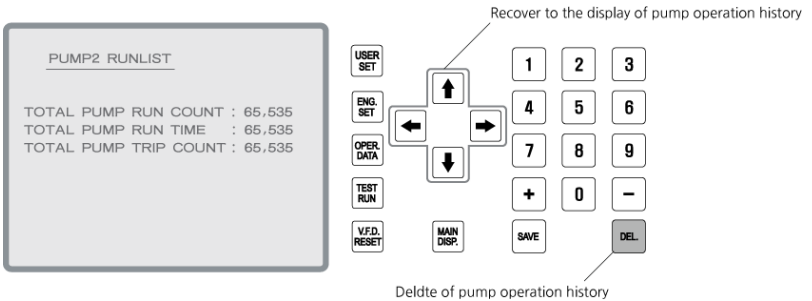

Chapter #5

Test Operation Keys of test operation

Test Operation Key

It is used for checking direction of motor rotation.

After turning off the STOP/START switch on panel, please operate this function.

1. Press Test Run key on main display..

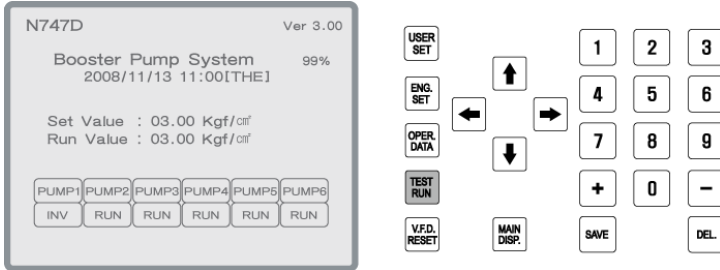

2. In the test run display, Choose desire pump with cursors.

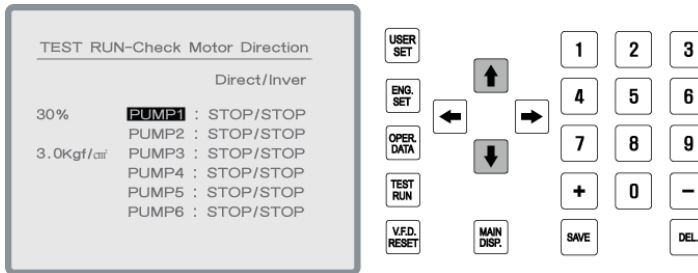

3. Use left/right cursor to select pump operation method.

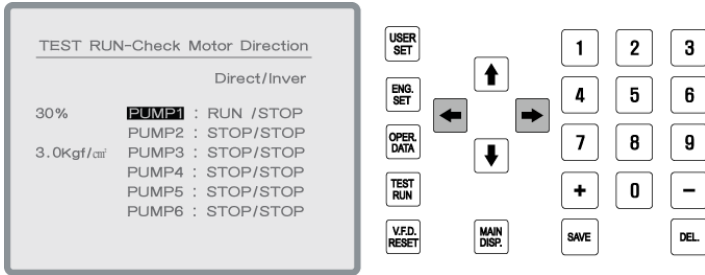

4. Using **+**, **-** Key, change the sensor correction value and Min operation ratio.

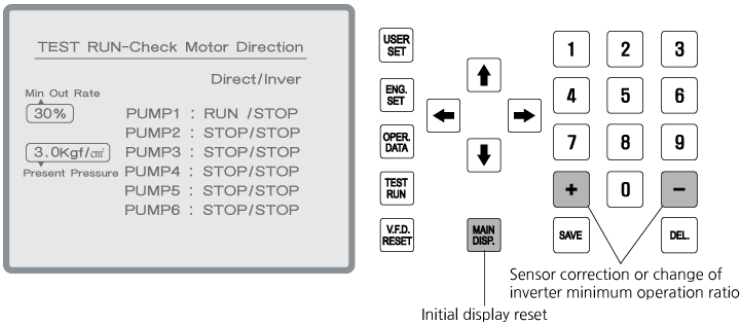

Chapter #6

Other Keys

1. Inverter reset Key

V.F.D. RESET Key is used to re-start inverter in inverter error state.

Up to 2 sets of inverters can be used, and pressing **V.F.D. RESET** Key resets the inverter in trouble among two inverters (Two inverters are optional)

2. Main screen Key

Pressing **MAIN DISP.** Key enables to move to initial screen.

3. Alarm display and reaction

When alarm is given, buzzer sounds and lamp blinks. At the same time, the alarm notes are displayed on LCD screen. To stop the buzzer, just press any key of the controller keys. Lamp keeps blinking until the root cause of alarming is fully cleared.

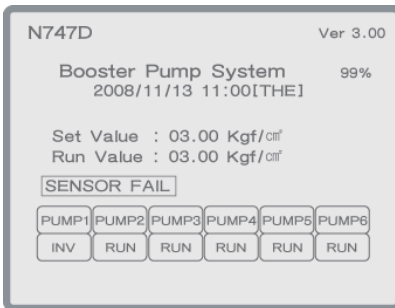

▶ Displaying items on LCD screen when alarm is given;

1. No water in the pipe line - Alarming low level
2. Motor overheating P1 TRIP - Motor overloaded
3. Sensor is abnormal - Sensor trouble
4. Inverter is abnormal (In emergent operating) - Inverter trouble.
5. Pressure is too high - High pressure alarm
6. Pressure is too low - Low pressure alarm

▶ If automatic operation is not available under low pressure alarming, please take one of below means.

1. Set one of the front panel switch of pump 1, pump 2, pump 3, pump 4, pump 5 and pump 6(if there are 6 pumps) as MANU, so that one pump can be started and increases the pressure up to the low alarm setting pressure.
2. Press "In Test Operating" key among the front switches, so that one pump can be started and increases the pressure up to the low alarm setting pressure.
3. Press "Stop/Start" switch of the front panel to make stop, then press again to start.

Chapter #7

Appendix

1. Control board arrangement and description
2. Check items
3. Procedure and manual for pump test operation
4. Emergent operation
5. RS-485 communication

1. Control board arrangement and description.

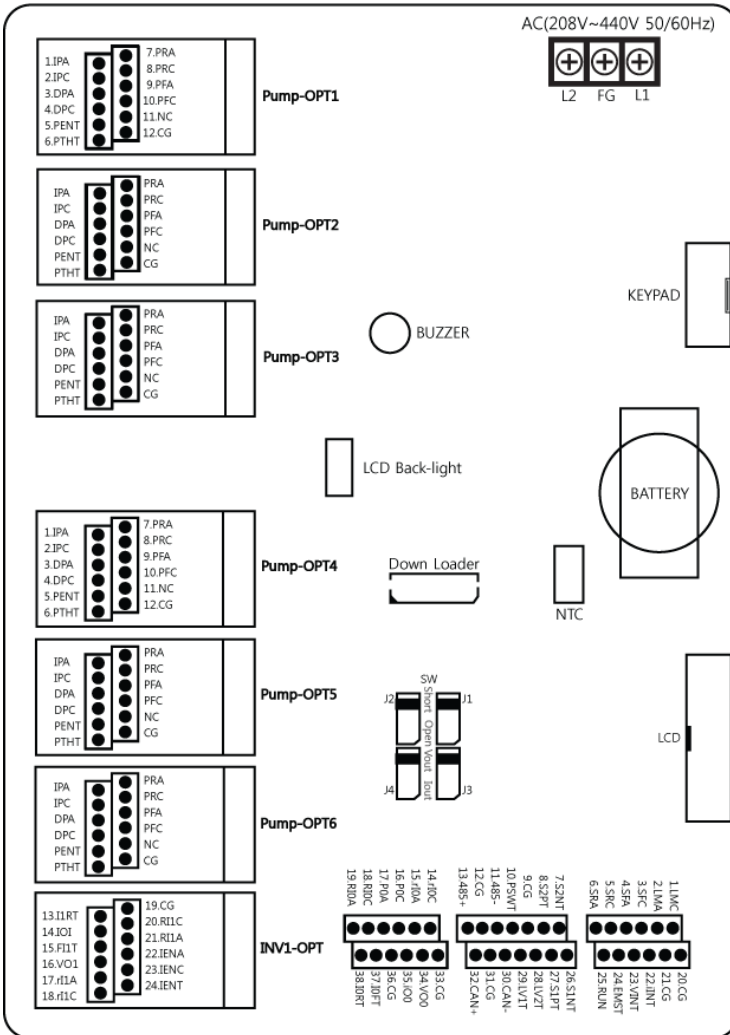

Main Board

1:	LMC	Error lamp relay C contact
2:	LMA	Error lamp relay A contact
3:	SFC	Sysetm error relay C contact
4:	SFA	Sysetm error relay A contact
5:	SRC	Sysetm operation Relay C contact
6:	SRA	Sysetm operation Relay A contact
7:	S2NT	Pressure sensor2 (-) terminal
8:	S2PT	Pressure sensor2 (+) terminal
9:	CG	Earthing common terminal
10:	PSWT	Emergency pressure swtch input terminal
11:	485-	RS485 signal Low terminal
12:	CG	RS485 signal earthing common terminal
13:	485+	RS485 signal High terminal
14:	RI0C	Inverter 0 initializing relay C contact
15:	RI0A	Inverter 1 initializing relay A contact
16:	PC	Mulifunction relay C contact
17:	PA	Mulifunction relay A contact
18:	RI0C	Inverter 0 operation relay C contact
19:	RI0A	Inverter 1 operation relay A contact
20:	CG	Earthing common terminal
21:	CG	Earthing common terminal
22:	iINT	Externally incoming signal current(4~20mA)
23:	VINT	Externally incoming signal voltage(0~10V)

24:	EMST	System emergency operation signal terminal
25:	RUN	System start/stop signal terminal
26:	S1NT	Pressure sensor1 (-) terminal
27:	S1PT	Pressure sensor1 (+) terminal
28:	LV2T	Low level sensor 2 input terminal
29:	LV1T	Low level sensor 1 input terminal
30:	CAN-	CAN signal low terminal
31:	CG	CAN signal earthing common terminal
32:	CAN+	CAN signal high terminal
33:	CG	Earthing common terminal
34:	VO0	inverter 0 frequeancy setup voltage(0~10V)
35:	iO0	inverter 0 frequeancy setup current(0~11V)
36:	CG	Earthing common terminal
37:	IOFT	Inverter 0 error recognition terminal
38:	IORT	Inverter 1 operation recognition terminal
J1	CAN terminating resistance SW(used when short)	
J2	RS485 terminating resistance SW(used when short)	
J3	Inverter 0 frequency setup: current/voltage adjusting SW (Vout: voltage, Iout: current)	
J4	Inverter 1 frequency setup: current/voltage adjusting SW (Vout: voltage, Iout: current)	
VR1	LCD display setup	
Battery	TIME IC backup battery	

Pump option board

1:	IPA	Inverter pump relay A contact
2:	IPC	Inverter pump relay C contact
3:	DPA	pump relay A contact
4:	DPC	pump relay C contact
5:	PENT	Pump recognition terminal
6:	PTHT	Pump overload terminal
7:	PRA	Pump operation relay A contact
8:	PRC	Pump operation relay C contact
9:	PFA	Pump operation Error A contact
10:	PFC	Pump operation Error C contact
11:	NC	Not in use
12:	CG	Common terminal of input terminal

Inverter option board

13:	I1RT	Inverter 1 operation recognition terminal
14:	i01	Inverter 1 frequency setup current(4~20mA)
15:	IENA	Inverter 1 pump relay A contact
16:	IENC	Inverter 2 pump relay C contact
17:	r11A	Inverter 2 initializing relay A contact
18:	r12C	Inverter 3 initializing relay C contact
19:	CG	Earthing common terminal
20:	VO1	Inverter 1 frequency setup voltage(0~10V)
21:	F11T	Inverter 1 error recognition terminal
22:	R11A	Inverter 1 operation relay A contact
23:	R11C	Inverter 1 operation relay C contact
24:	IENT	Inverter 1 operation status recognition terminal

2. Check items

1. No operation is started when powered ON;
 - (1) Check power voltage (208V~440V).
 - (2) Check power, wire short and contact terminals.

2. When powered ON, only LCD Back Light is turned on;
 - (1) Turn VR counterclockwise with PIN driver.
 - (2) Check cables connected to LCD.

3. No front Key works;
 - (1) Check cables connected to control board Key.

4. After set front panel switches for pump #1, Pump #2 and Pump #3 at AUTO position, no pump is not identified on the LCD screen;
 - (1) Check switch contact points.
 - (2) Verify the shortages of 5. PENT and 12. CG wire of Pump-OPT board.
 - (3) Check the contact point of 5. PENT and 12. CG wire of Pump-OPT board.
(Verify LED ON state of Pump-OPT board.)

5. "Start/Stop" switch of the front panel does not work;
 - (1) Check switch contact points.
 - (2) Verify the shortages of 20.CG and 25. Run wire of main board.
 - (3) Verify the contact points of 20.CG of main board and 25. Run wire. (Verify LED ON state of main board.)

6. The output of inverter is not sufficient;

(EX. While front LCD shows 100%, internal inverter operates in 50Hz.)

 - (1) Adjust DAC value in installer's settings.

7. While the inverter is displayed on front LCD, pump does not work;
 - (1) Check wire shortage and contact points of 18.RI0C and 19.RI0A of main board.
 - (2) Verify if any short raises in 18. RI0C and 19. RI0A wire. (RUN signal work when short)
 - (3) Verify the shortages and contact points of 35.VO0 and 36.CGwire.
 - (4) Check DC voltage of 35. VO0 and 36. CG wire in main board.
(EX. DC 5V = 30Hz, DC10V = 60Hz)

8. MC does not work in each pump;
 - (1) Check if each MC power is 220 V.
 - (2) Verify shortages and contact points of 1. IPA, 2. IPC, 3. DPA and 4. DPC wire in Pump-OPT.

9. There is big gap between analog pressure gauge and the current pressure of LCD screen;
 - (1) Check the maximum pressure sensor value in use.
 - (2) Adjust the maximum pressure sensor value in the installer's setting screen.

10. Analog pressure gauge is very close to the current pressure of LCD screen;
 - (1) Adjust sensor correction value in the installer's setting screen.

11. Main pump and auxiliary pump operate continuously;
 - (1) Check the rotation direction of the pump (it's possible in test operating).
 - (2) Re-set the operating pressure and time of the auxiliary pump.

12. Auxiliary pump operates frequently;
 - (1) In the user setting screen, re-set the operating pressure and time of auxiliary, sequential stop pressure and time.

13. Only main pump operates.
 - (1) In the user setting screen, re-set the shift time of main pump.
 - (2) Shift the pump by operator with the front switch.

14. Frequent starting phenomenon happens in emergent operation due to the inverter trouble;
 - (1) In the user setting screen, re-set the sequential operation pressure and time, sequential stop pressure and time.

15. It is changed to "sequential operation 2" by user;
 - (1) Adjust the deviation of pressure switch.
16. Various alarms raise (Buzzer, Lamp operates);
 - (1) Enter front numeric Key and initial screen Key once. (Buzzer OFF, Lamp OFF)
 - (2) Check the caused troubles and take corrections.

17. Auto-operation is not available in low pressure alarming;
- (1) Set the pressure time of low pressure alarm more than 10 seconds, then stop the front panel "START/STOP" switch and re-start.
 - (2) Set one of the front panel switch of pump 1, pump 2, pump 3 and pump 4 as MANU, so that one pump can be started and increases the pressure up to the low alarm setting pressure.
18. Control of inverter is not available;
- (1) Check the inverter control method - voltage method, or current control method;
 - (2) If inverter control method is by current, check whether the J3 switch of main board is lout direction. If the control method is by voltage, it should be opposite direction (Ex-factory default setting is voltage control method).

3. Pump test operation



Thank you for your selection of our boost pump system.

In this section, check items, procedures and manuals for test operation are summarized for our boost pump users.



The least items to be entered essentially for test operation must be entered.

1. Check items before test operation

- Check site circumstance
 - 1) Is water sufficient in water tank?
 - 2) Is power connected?
 - 3) Is the piping connection well?

2. Procedure of pump test operation





Before the site test operation, make sure to confirm below items.

- 1) Has water been supplied to the site?
- 2) Is the wiring of panel and motor well connected.
- 3) Is the power supplied?

3. Manual for boost pump system test operation

- 1) Check if water is sufficient in the water tank.
- 2) Check if power cables of motor and panel are connected.
- 3) Open the water tank valve and inlet/outlet valves of pump.

- 4) Remove all air by opening air cocks of inlet and pump, until water is dispensed only.
- 5) Close air cocks.
- 6) Turn on all internal NFB (breaker) of panel.
- 7) Turn on the power switch of the panel front.
- 8) If it is 3 pump system, then set switches of PUMP#1, PUMP#2 and PUMP#3 at AUTO position.
- 9) Press test operation Key on the controller (the rotation direction of the motor fan is counterclockwise). Press  Key once then direct-input operation starts, press twice then stops. Again press  Key once then inverter starts, press twice then stops. If the motor rotation direction is wrong, re-connect of the direct-input starting in RST or RTS order. In case of inverter starting, change the inverter output terminal from UVW to U'V'W'.
- 10) Once rotation direction is confirmed, then verify if the set pressure of controller LCD screen is the desired input value (in case of change set pressure, correct the date · set pressure according to this manual printed inside of the panel).
- 11) When all steps are completed, set “START / STOP” switch at “START” and start the operation.

1. Emergency operation

Types of emergent operation

Emergent operation system is required against to any emergency of water supply pump for its special requirement.

- In case of inverter failure, automatic emergent operation / sequential 1 operation / sequential 2 operation

1. Automatic emergent operation in inverter failure

Reason : In case of inverter failure

Starting method :

If inverter is in failure, RPM of main pump is out of control.

Even in such situation, as water shall be supplied until A/S team arrives, therefore, automatic emergent operation (pressure method) is carried out.

Its operating principle is ; pipe pressure can be detected by pressure transmitter then normal operation is sustained by program control of controller in all functions such as shift operation excluding RPM control.

Set starting deviation pressure value becomes the condition of pump starting when operation mode is switched to emergent automatic operation. Setting of starting deviation pressure is available, however its initial value is set as 0.5bar.

In this case, if set pressure is 4.0 bar, then sequential auxiliary pump starts if it's not above 3.5bar.

As the condition to stop depend on the set value of auxiliary stop deviation pressure, if auxiliary stop deviation value is 0.5bar, then it shall be 4.5bar to stop the pump sequentially.

In this process, after all pumps stop and then if it's 3.5bar or less then it operates again.

The starting deviation pressure can be corrected through sequential operation pressure and sequential stop pressure items of "User setting [1]". Please note that if the value is too small, the frequency of starting/stop increases. Please call our A/S team to get support while the pump operates under emergent automatic operation mode.

Indications :

In case of inverter failure, auto emergent operation is carried out automatically and the failure notice is indicated in main screen. In the bottom of present pressure of initial screen, the notice of "Inverter is abnormal" is indicated, so please make sure to check it in daily check.

2. sequential 1 operation

Reason : When replacing of abnormal inverter

Starting method :

Starting method is same as the principle of automatic emergent operation in case of inverter failure. In "sequential 1 operation", emergent operation is carried out forcibly as because water can be supplied only by pump when inverter shall be replaced due to inverter failure. sequential 1 operation can be carried out through "Installer's setting". "Installer's setting" is only for authorized engineers, but not disclosed to general consumers due to the possibilities including serious failure or accident by unauthorized change of settings.

Caution : User's setting mode shall be accessed only by authorized engineers.

3. sequential 2 operation

Reason : In case inverter and pressure transmitter failed at the same time.

Starting method:

Operation of ON-OFF control method is carried on by Max/Min set value of pressure switch. As it is under control of controller, general functions such as shift operation can be carried out. Also water is supplied continuously, however, the pipe pressure is little bit unstable than RPM control due to the characteristics of ON/OFF of pressure switch. Therefore, in case of sequential 2 operation, please call our A/S team immediately to get support.

3. sequential 3 operation

Reason :

This is the last emergent operation method to be carried when normal operation is unavailable due to the failure of most of core components such as inverter, pressure transmitter, pressure switch, controller and etc.

Starting method:

Minimal water can be supplied through operation with #1 pump only by pressure switch, if the “operation select” switch of the panel is set at emergency position manually. In this case, please call our A/S team immediately to get support.

Occurrence frequency : It is very rare to operate by the emergency switch.

5. RS-485

■ Communication specification

Item	Specification
Com Speed	1200/2400/4800/9600/19200 bps
Control procedure	Async communication
Communication system	Half duplex system
Bit	8 bit
Stop bit	1 bit
Error Check(CRC16)	2 byte
Parity check	None

Communication Protocol

ModBus- RTU Protocol

Function code

Code	Name
0x03	Read Hold Register
0x06	Preset Single Register

READ

- Query (example)

start	Slave ID	Function	start Add Hi	Start Add Lo	No Hi	No Lo	CRC				END						
3.5byte Time	X	X	0	3	4	0	0	C	0	0	0	1	X	X	X	X	3.5byte Time

- response

start	Slave ID	Function	byte Count	Data Hi	Data lo	CRC				END					
3.5byte Time	X	X	0	3	0	2	0	0	3	7	X	X	X	X	3.5byte Time

Single Write

- Query (example - Pressure 5.5bar)

start	Slave ID	Function	Add Hi	Add Lo	Data Hi	Data Lo	CRC				END						
3.5byte Time	X	X	0	6	4	0	0	C	0	0	3	7	X	X	X	X	3.5byte Time

- response

start	Slave ID	Function	Add Hi	Add Lo	Data Hi	Data Lo	CRC				END						
3.5byte Time	X	X	0	6	4	0	0	C	0	0	3	7	X	X	X	X	3.5byte Time

Setting for communication

Installer setting [3] (Refer Page 38 ~ Page 40)

- RS-485
- Slave ID

BOOSTER PUMP SYSTEM N747D

- BAUD RATE
- DELAY TIME
- DRIVE MODE

■ Diagnosis

Check Points	Remark
Check connection of N747D and equipment	Refer Page 53 Main board 11.485- 485 signal low 12.GND 485 Ground 13.485+ 485 signal high
Check whether RS485 is use or not	Refer Page 38
Check communication	Refer Page 38
Check N747D Slave ID	Protocol Slave ID should be Same with N747D Slave (Refer Page 38)
Check the start of master	
Installer program (Format)	

■ Parameter ADDRESS

Address	Parameter	Scale	Unit	R/W	내용
0x4000	Program version	0.01		R	0~65535
0x4001	Operation mode			R	0 : Controller key 1: RS-485
0x4002	System operation			R/W	0: Stop 1: RUN

0x4003	Pump			R	Bit Low Byte Bit 0: 1 Bit 1: 2 Bit 2: 3 Bit 3: 4 Bit 4: 5 Bit 5: 6 Bit 6: OPTION
0x4004	Operation method			R	0:Inverter(Fix) 1:Inverter(Move) 2:Sequential operation 1 3:Sequential operation 2
0x4005	Pump 1 output	1	%	R	0~100%
0x4006	Pump 2 output	1	%	R	0~100%
0x4007	Pump 3 output	1	%	R	0~100%
0x4008	Pump 4 output	1	%	R	0~100%
0x4009	Pump 5 output	1	%	R	0~100%
0x400A	Pump 6 output	1	%	R	0~100%
0x400B	Option inverter output	1	%	R	0~100%
0x400C	Setting Pressure	0.1	bar	R/W	0~250
0x400D	Current Pressure	0.1	bar	R	0~250
0x400E	Pump1 operation number	1	Num -ber	R	0~65535
0x400F	Pump2 operation number	1	Num -ber	R	0~65535
0x4010	Pump3 operation number	1	Num -ber	R	0~65535
0x4011	Pump4 operation number	1	Num -ber	R	0~65535
0x4012	Pump5 operation number	1	Num -ber	R	0~65535
0x4013	Pump6 operation number	1	Num -ber	R	0~65535
0x4014	Pump1 trip number	1	Num -ber	R	0~65535
0x4015	Pump2 trip number	1	Num -ber	R	0~65535
0x4016	Pump3 trip number	1	Num -ber	R	0~65535

BOOSTER PUMP SYSTEM N747D

Address	Parameter	Scale	Unit	R/W	Content
0x4017	Pump4 trip number	1	Num-ber	R	0~65535
0x4018	Pump5 trip number	1	Num-ber	R	0~65535
0x4019	Pump6 trip number	1	Num-ber	R	0~65535
0x401A	Pump1 operation time	1	hour	R	0~65535
0x401B	Pump2 operation time	1	hour	R	0~65535
0x401C	Pump3 operation time	1	hour	R	0~65535
0x401D	Pump4 operation time	1	hour	R	0~65535
0x401E	Pump5 operation time	1	hour	R	0~65535
0x401F	Pump6 operation time	1	hour	R	0~65535
0x4020	Inverter option Pump operation time	1	hour	R	0~65535
0x4021	Operation Statue			R	<p>Content for each pump</p> <p>Low Byte : Direct start pump</p> <p>Bit 0: 1 Bit 1: 2 Bit 2: 3</p> <p>Bit 3: 4 Bit 4: 5 Bit 5: 6</p> <p>High Byte : Inverter Pump</p> <p>Bit 8: 1 Bit 9: 2 Bit 10: 3</p> <p>Bit 11: 4 Bit 12: 5 Bit 13: 6</p> <p>Bit 14: OPTION</p>

0x4022	Current trip information			R	<p>Content for each pump</p> <p>Low Byte : Trip content</p> <p>Bit 0 : High pressure</p> <p>Bit 1: Low pressure</p> <p>Bit 2: Pump over current</p> <p>Bit 3: Inverter1</p> <p>Bit 4: Low level Bit 5: Sensor</p> <p>Bit 6: Inverter2(option)</p> <p>Bit 7: Emergent operation</p> <p>High Byte : Trip pump</p> <p>Bit 8: pump1 Bit 9: pump 2</p> <p>Bit 10: pump 3 Bit 11: pump 4</p> <p>Bit 12: pump 5 Bit 13: pump 6</p>
--------	--------------------------	--	--	---	--